

# Optimo 33L

FR

NL

DE

EN

ES

IT

PT

RU

KK

UK

BG

RO

HR

CZ

HU

SK



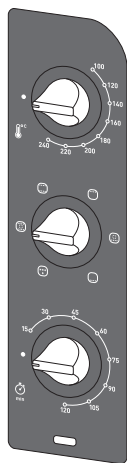
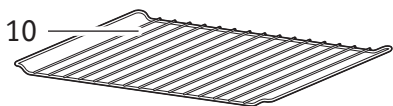
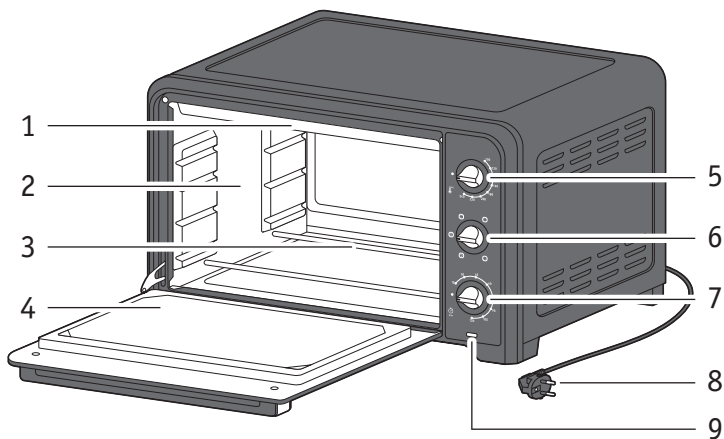

\* selon modèle - afhankelijk van het model - je nach Modell - depending on the model - según el modelo - in base al modelo - consoante o modelo - В зависимости от модели - үлгіге байланысты - залежно від моделі - В зависимости от модели - În funcție de model - ovisno o modelu - v závislosti na modelu - modelltól függően - v závislosti na modeli

## DESCRIPTION

- 1 Résistance supérieure
- 2 Parois aluminium
- 3 Résistance inférieure
- 4 Porte double parois
- 5 Bouton de réglage température
- 6 Bouton des fonctions

## BESCHRIJVING

- 1 Bovenste verwarmingselement
- 2 Aluminium wanden
- 3 Onderste verwarmingselement
- 4 Dubbelwandige deur
- 5 Regelbare thermostaatknop
- 6 Functieknop

## BESCHREIBUNG

- 1 Oberes Heizelement
- 2 Aluminiumwände
- 3 Unteres Heizelement
- 4 Doppelwandige Tür
- 5 Temperaturregler
- 6 Funktionsknopf

## DESCRIPTION

- 1 Top heating element
- 2 Aluminium walls
- 3 Bottom heating element
- 4 Double-wall door
- 5 Temperature control button
- 6 Functions button

## DESCRIPCIÓN

- 1 Resistencia superior
- 2 Paredes aluminio
- 3 Resistencia inferior
- 4 Puerta de doble cristal
- 5 Botón de ajuste de temperatura
- 6 Botón de funciones

## DESCRIZIONE

- 1 Elemento riscaldante superiore
- 2 Pareti in alluminio
- 3 Elemento riscaldante inferiore
- 4 Porta a doppia parete
- 5 Pulsante di regolazione della temperatura
- 6 Pulsante funzioni

- 7 Bouton de minuterie
- 8 Cordon d'alimentation
- 9 Voyant de fonctionnement
- 10 Grille réversible
- 11 Plat lèche-frite\*

- 7 Timerknop
- 8 Snoer
- 9 Aan/uit-controlelampje
- 10 Omkeerbaar grillrooster
- 11 Ovenschaal\*

- 7 Timer-Knopf
- 8 Netzkabel
- 9 Betriebskontrollleuchte
- 10 Umkehrbarer Grillrost
- 11 Backblech\*

- 7 Timer button
- 8 Power cord
- 9 Power indicator light
- 10 Reversible grill rack
- 11 Food tray\*

- 7 Botón de temporizador
- 8 Cable de alimentación
- 9 Indicador de funcionamiento
- 10 Parrilla de grill reversible
- 11 Bandeja de comida\*

- 7 Pulsante timer
- 8 Cavo di alimentazione
- 9 Spia di alimentazione
- 10 Griglia di cottura reversibile
- 11 Vassoio degli alimenti\*

\* selon modèle - afhankelijk van het model - je nach Modell - depending on the model - según el modelo - in base al modello - consoante o modelo - В зависимости от модели - үлгіге байланысты - залежно від моделі - В зависимости от модели - În funcție de model - ovisno o modelu - v závislosti na modelu - modellől függően - v závislosti na modeli

## DESCRIÇÃO

- 1 Resistência superior
- 2 Paredes alumínio
- 3 Resistência inferior
- 4 Porta de parede dupla
- 5 Botão deregulação da temperatura
- 6 Botão das funções
- 7 Botão temporizador
- 8 Cabo de alimentação
- 9 Luz piloto de funcionamento
- 10 Grelha reversível
- 11 Tabuleiro\*

## ОПИСАНИЕ

- 1 Верхний нагревательный элемент
- 2 Алюминиевые стенки
- 3 Нижний нагревательный элемент
- 4 Двухслойная дверца
- 5 Кнопка контроля температуры
- 6 Кнопка выбора функций
- 7 Кнопка таймера
- 8 Кабель питания
- 9 Индикатор питания
- 10 Двухсторонняя решетка для гриля
- 11 Противень\*

## СИПАТТАМА

- 1 Жоғарғы қыздыру элементі
- 2 Алюминий қабырғалар
- 3 Төменгі қыздыру элементі
- 4 Қос қабырғалы есік
- 5 Температураны басқару түймесі
- 6 Функциялар түймесі
- 7 Таймер түймесі
- 8 Қуат сымы
- 9 Қуат индикаторының шамы
- 10 Аударуға болатын гриль сәресі
- 11 Тамақ науасы\*

## ОПИС

- 1 Верхній нагрівальний елемент
- 2 Алюмінієві стінки
- 3 Нижній нагрівальний елемент
- 4 Дверцята з подвійними стінками
- 5 Кнопка регулювання температури
- 6 Кнопка вибору функцій
- 7 Кнопка таймера
- 8 Шнур живлення
- 9 Світловий індикатор живлення
- 10 Двостороння решітка для гриля
- 11 Піднос\*

## ОПИСАНИЕ

- 1 Горен нагревателен елемент
- 2 Алюминиеви стени
- 3 Долен нагревателен елемент
- 4 Вратичка с две стени
- 5 Бутон за контрол на температурата
- 6 Бутон за функции
- 7 Бутон за таймер
- 8 Захранващ кабел
- 9 Индикаторна лампичка за захранване
- 10 Обръщаща се скара
- 11 Тава за храна\*

\* selon modèle - afhankelijk van het model - je nach Modell - depending on the model - según el modelo - in base al modello - consoante o modelo - В зависимости от модели - үлгіге байланысты - залежно від моделі - В зависимости от модели - In functie de model - ovisno o modelu - v závislosti na modelu - modellől függően - v závislosti na modeli

## DESCRIERE

- 1 Element de încălzire superior
- 2 Pereți din aluminiu
- 3 Element de încălzire inferior
- 4 Ușă cu pereți dubli
- 5 Buton de control al temperaturii
- 6 Buton de funcții
- 7 Buton temporizator
- 8 Cordon de alimentare
- 9 Indicator luminos de alimentare
- 10 Grătar reversibil
- 11 Tavă de alimente\*

## OPIS

- 1 Gornji grijač
- 2 Aluminijske pregrade
- 3 Donji grijač
- 4 Vrata s dvostrukom stjenkom
- 5 Tipka za podešavanje temperature
- 6 Tipka za odabir funkcije
- 7 Tipka timera
- 8 Priključni vod
- 9 Signalno svjetlo napajanja
- 10 Okretna rešetka za roštilj
- 11 Pladanj za hranu\*

## POPIS

- 1 Horní topné těleso
- 2 Hliníkové stěny
- 3 Dolní topné těleso
- 4 Dveře s dvojitou stěnou
- 5 Tlačítko regulace teploty
- 6 Funkční tlačítka
- 7 Tlačítko časovače
- 8 Napájecí kabel
- 9 Kontrolka napájení
- 10 Otočný grilovací stojan
- 11 Táč na potraviny\*

## LEÍRÁS

- 1 Felső fűtőelem
- 2 Alumínium falak
- 3 Alsó fűtőelem
- 4 Dupla falú ajtó
- 5 Hőmérsékletszabályozó gomb
- 6 Funkciógomb
- 7 Időzítő gomb
- 8 Hálózati kábel
- 9 Tápellátás jelzőfény
- 10 Megfordítható grillrács
- 11 Ételtartó tálca\*

## POPIS

- 1 Horné výhrevné těleso
- 2 Hliníkové stěny
- 3 Dolné výhrevné těleso
- 4 Dveře s dvojitou stenou
- 5 Tlačítko regulácie teploty
- 6 Funkčné tlačidlo
- 7 Tlačidlo časovača
- 8 Napájací kábel
- 9 Kontrolka napájania
- 10 Otočný grilovací stojan
- 11 Távka na potraviny\*

\* selon modèle - afhankelijk van het model - je nach Modell - depending on the model - según el modelo - in base al modello - consoante o modelo - В зависимости от модели - улігіе байланысты - залежно від моделі - В зависимости от модели - În funcție de model - ovisno o modelu - v závislosti na modelu - modellől függően - v závislosti na modeli

1

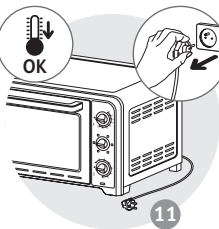
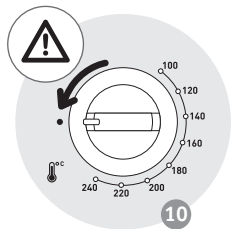
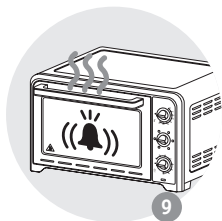
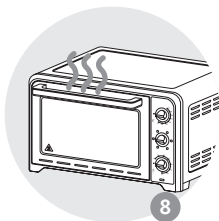
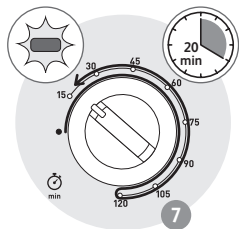
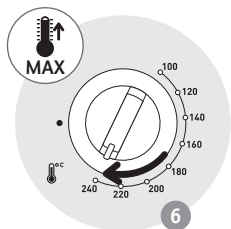
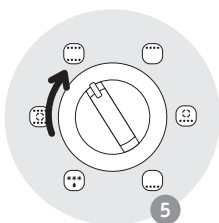
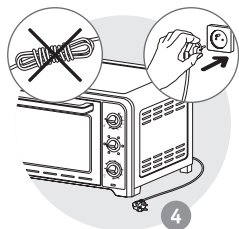
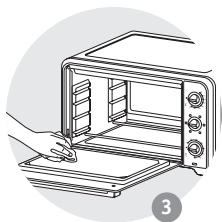
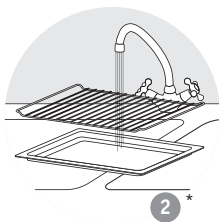
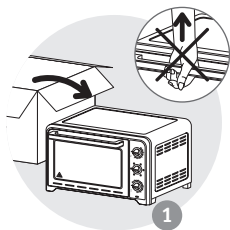

\* selon modèle  
afhankelĳk van het model  
je nach Modell  
depending on the model  
según el modelo  
in base al modelo  
consoante o modelo  
В зависимости от модели  
үлгіге байланысты  
залежно від моделі  
В зависимости от модели  
In funcție de model  
ovisno o modelu  
v závislosti na modelu  
modelltól függően  
v závislosti na modeli

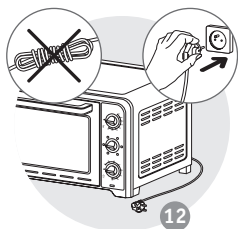

12

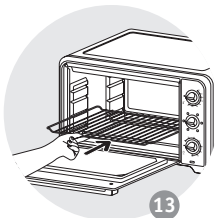

13

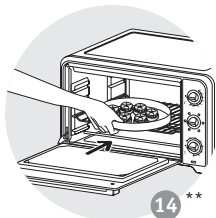

14 \*\*

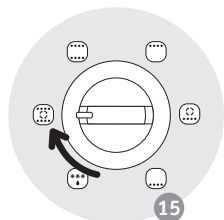

15

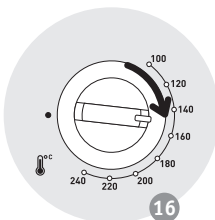

16

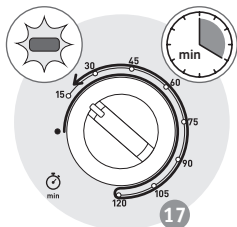

17

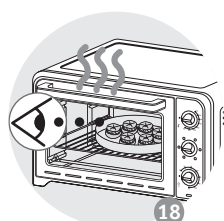

18

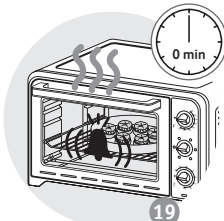

19

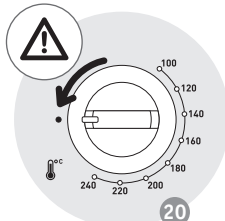

20

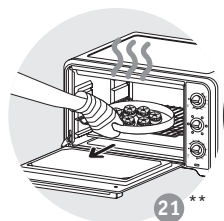

21 \*\*

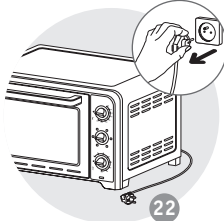

22

\*\* Plat non fourni avec l'appareil  
 Schaal niet bij het apparaat inbegrepen  
 Platte nicht im Lieferumfang inbegriffen  
 The dish is not supplied with the appliance  
 El plato no es suministrado con el aparato  
 Piatto non fornito con l'apparecchio  
 Travessa não fornecida com o aparelho  
 Блюдо не входит в комплект  
 Құрылғымен бірге тәріпке  
 қамтамасыз етілмейді  
 Блюдо не входит в комплект  
 поставки приладу  
 Съдът не се предоставя с уреда  
 Tava nu este furnizată cu aparatul.  
 Posuđe se ne isporučuje uz uređaj  
 Miska není dodávána se spotřebičem  
 A tál nem a készülék tartozéka  
 Miska sa nedodáva so spotrebičom

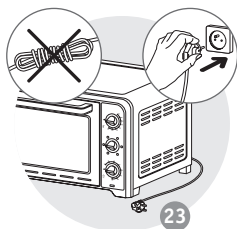

23

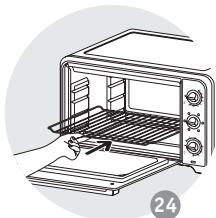

24

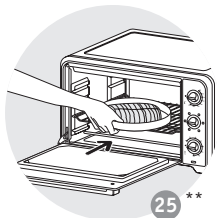

25 \*\*

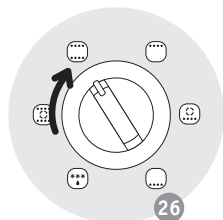

26

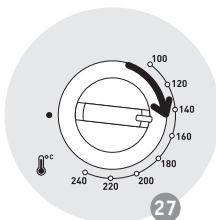

27

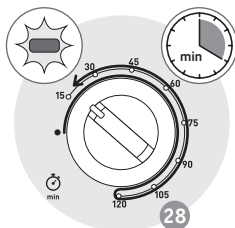

28

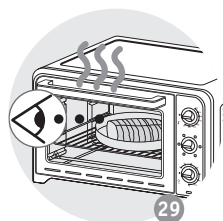

29

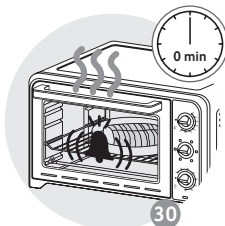

30

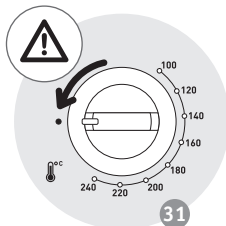

31

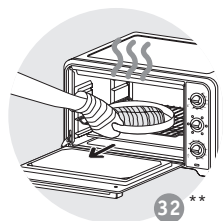

32 \*\*

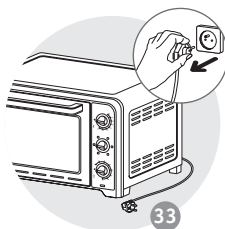

33

\*\* Plat non fourni avec l'appareil  
 Schaaf niet bij het apparaat inbegrepen  
 Platte nicht im Lieferumfang inbegriffen  
 The dish is not supplied with the appliance  
 El plato no es suministrado con el aparato  
 Piatto non fornito con l'apparecchio  
 Travessa não fornecida com o aparelho  
 Блюдо не входит в комплект  
 Құрылғымен бірге тәріпке қамтамасыз етілмейді  
 Блюдо не входит в комплект поставки прибора  
 Съдът не се предоставя с уреда  
 Tava nu este furnizată cu aparatul.  
 Posude se ne isporučuje uz uređaj  
 Miska není dodávána se spotřebičem  
 A tálnem a készülék tartozéka  
 Miska sa nedodáva so spotrebičom



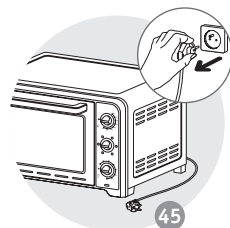
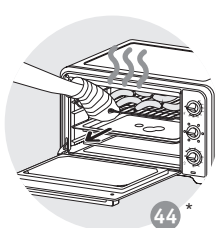
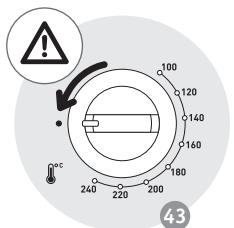
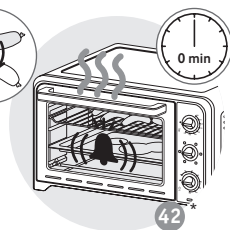
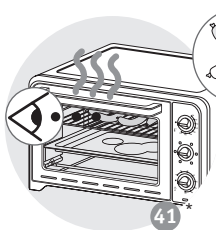
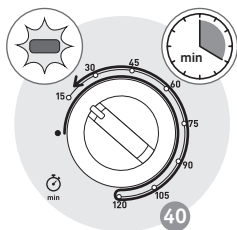
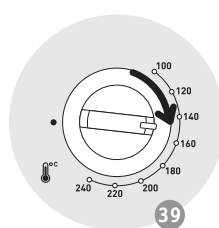
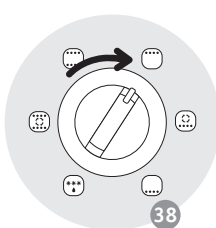
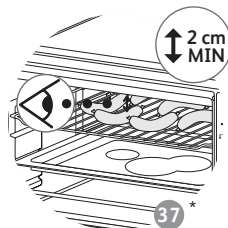
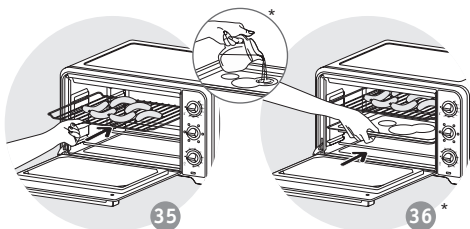
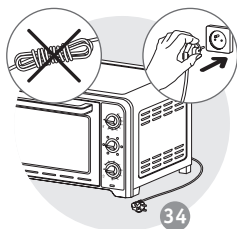

\* selon modèle - afhankelijk van het model - je nach Modell - depending on the model - según el modelo - in base al modelo - consoante o modelo - В зависимости от модели - улігіе байланысты - залежно від моделі - В зависимости от модели - În funcție de model - ovisno o modelu - v závislosti na modelu - modelltól függően - v závislosti na modeli

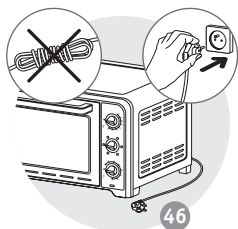

46

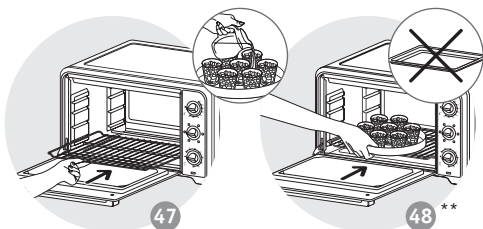

47

48 \*\*

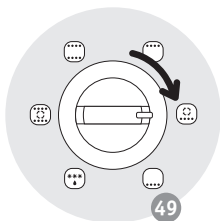

49

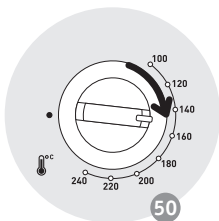

50

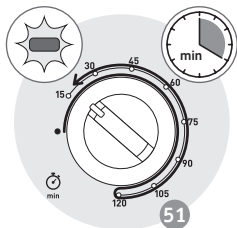

51

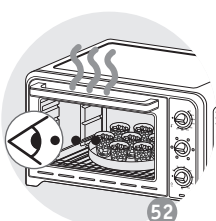

52

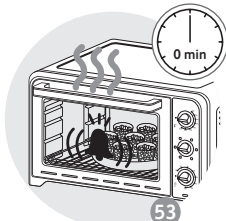

53

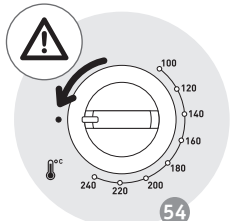

54

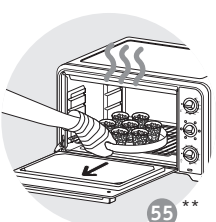

55 \*\*

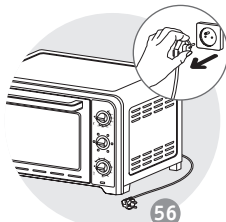

56

\*\* Plat non fourni avec l'appareil  
 Schaaf niet bij het apparaat inbegrepen  
 Platte nicht im Lieferumfang inbegriffen  
 The dish is not supplied with the appliance  
 El plato no es suministrado con el aparato  
 Piatto non fornito con l'apparecchio  
 Travessa não fornecida com o aparelho  
 Блюдо не входит в комплект  
 Құрылғымен бірге тәрепке  
 қамтамасыз етілмейді  
 Блюдо не входит в комплект  
 поставки приладу  
 Съдът не се предоставя с уреда  
 Tava nu este furnizată cu aparatul.  
 Posude se ne isporučuje uz uređaj  
 Miska není dodávána se spotřebičem  
 A tál nem a készülék tartozéka  
 Miska sa nedodáva so spotrebičom

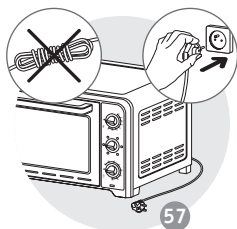

57

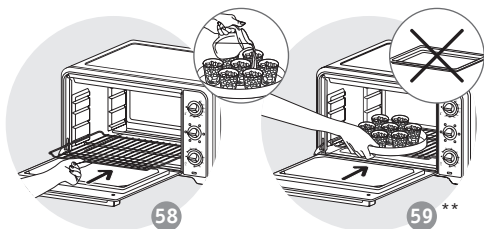

58

59 \*\*

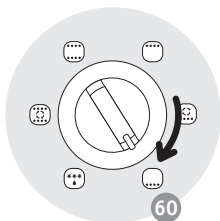

60

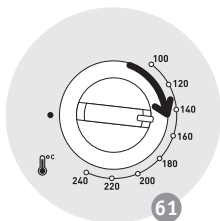

61

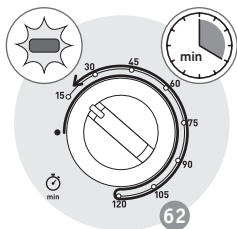

62

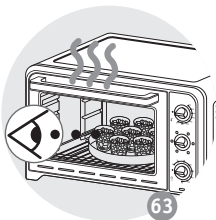

63

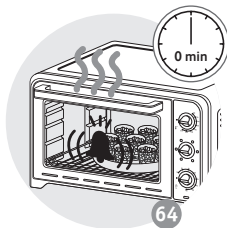

64

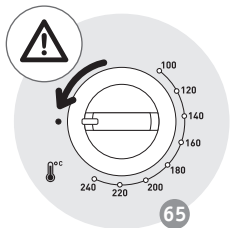

65

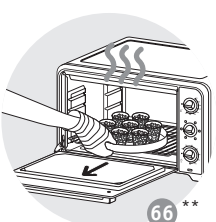

66 \*\*

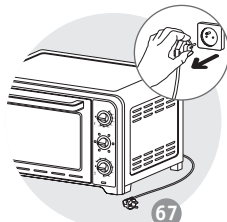

67

\*\* Plat non fourni avec l'appareil  
 Schaaf niet bij het apparaat inbegrepen  
 Platte nicht im Lieferumfang inbegriffen  
 The dish is not supplied with the appliance  
 El plato no es suministrado con el aparato  
 Piatto non fornito con l'apparecchio  
 Travessa não fornecida com o aparelho  
 Блюдо не входит в комплект  
 Құрылғымен бірге тәрелке  
 қамтамасыз етілмейді  
 Блюдо не входит в комплект  
 поставки приладу  
 Съдът не се предоставя с уреда  
 Tava nu este furnizată cu aparatul.  
 Posude se ne isporučuje uz uređaj  
 Miska není dodávána se spotřebičem  
 A tál nem a készülék tartozéka  
 Miska sa nedodáva so spotrebičom

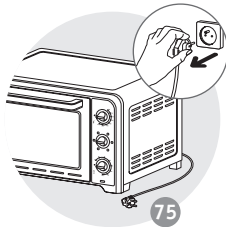
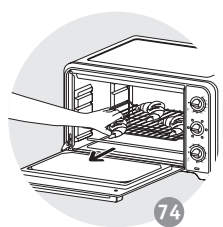
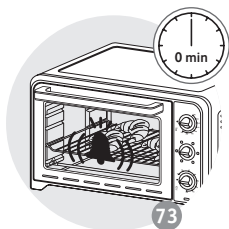
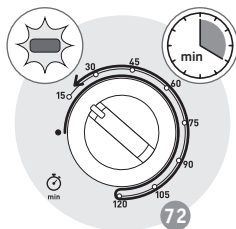
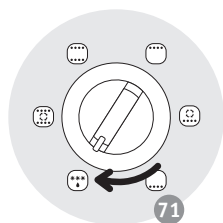
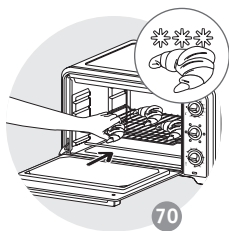
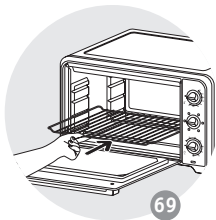
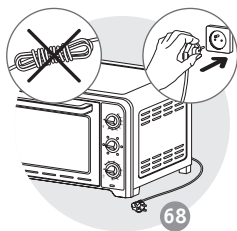

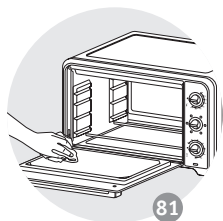
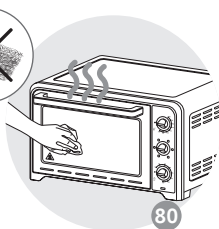
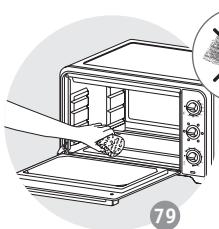
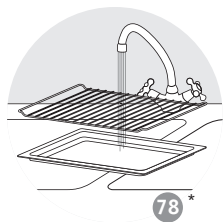
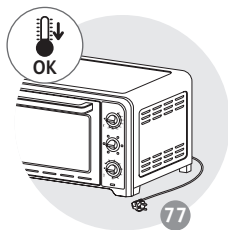
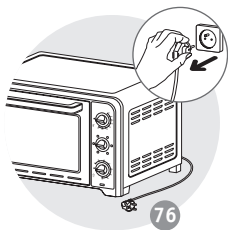

\* selon modèle - afhankelijk van het model - je nach Modell - depending on the model - según el modelo - in base al modelo - consoante o modelo - В зависимости от модели - үлгіге байланысты - залежно від моделі - В зависимости от модели - În funcție de model - ovisno o modelu - v závislosti na modelu - modelltól függően - v závislosti na modeli



	x4			10mins	240	18
	870g			10mins	230	56
	750g			10mins	240	40
	500g			-	240	57
	1000g			-	240	78
	x4			-	240	22 
	x8			-	240	15 
	350g			10mins	210	15
				10mins	240	40
	350g			10mins	240	15
				-	240	26
				10mins	200	42
				10mins	200	22
				10mins	200	35
	x6			10mins	150	10
	x6			10mins	200	18
				10mins	230	55
				10mins	240	25

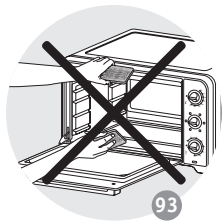
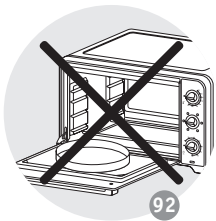
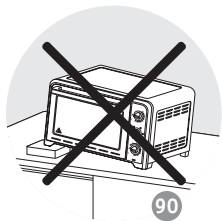
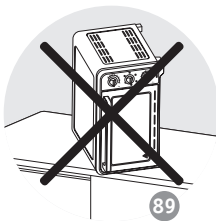
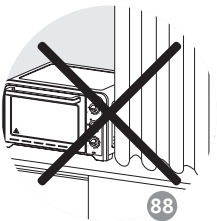
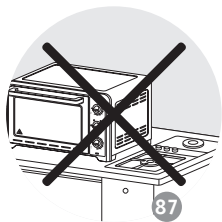
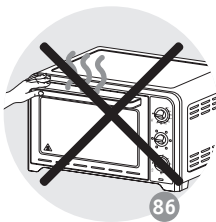
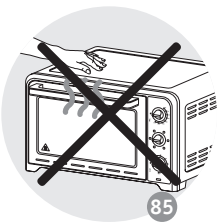
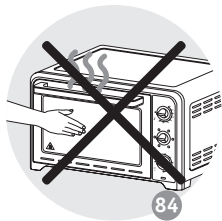
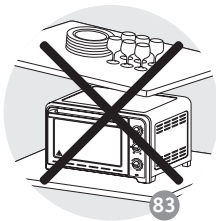
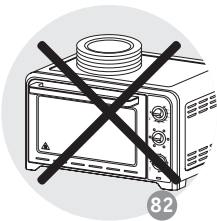











9100026922