

# Tefal®

EN

## Extra Crisp



tefal.co.uk  
www.tefal.com.au

## SAFETY INSTRUCTION

- This appliance is intended to be used in household only. It is not intended to be used in the following applications, and the guarantee will not apply for:
  - staff kitchen areas in shops, offices and other working environments;
  - farm houses;
  - by clients in hotels, motels and other residential type environments;
  - bed and breakfast type environments.
- This appliance is not intended to be operated by means of an external timer or separate remote-control system.
- If the power supply cord is damaged, it must be replaced by the manufacturer, its service agent or similarly qualified persons in order to avoid a hazard.
- This appliance is not intended for use by persons (including children) with reduced physical, sensory or mental capabilities, or lack of experience and knowledge, unless they have been given supervision or instruction concerning use of the appliance by a person responsible for their safety.
- Children should be supervised to ensure that they do not play with the appliance.
-  The temperature of accessible surfaces may be high when the appliance is operating. Do not touch the hot surfaces of the appliance.
- Clean removable parts with a non abrasive sponge and dishwashing liquid or in a dishwasher (depending on model).
- Clean the inside and the outside of the appliance with a damp sponge or cloth. Please refer to the «Cleaning» section of the instructions for use.
- The appliance can be used up to an altitude of 4000 m.

## Do

- Read and follow the instructions for use. Keep them safe.
- Remove all packaging materials and any promotional labels or stickers from your appliance before use. Be sure to also remove any materials from underneath the removable bowl (depending on model).
- Check that the voltage of your mains network corresponds to the voltage given on the rating plate on the appliance (alternative current).
- Given the diverse standards in effect, if the appliance is used in a country other than that in which it is purchased, have it checked by an approved Service Centre.
- Use the appliance on a flat, stable, heat-resistant work surface away from water splashes.
- Always unplug your appliance: after use, to move it, or to clean it.
- In the event of fire, unplug the appliance and smother the flames using a damp tea towel.
- To avoid damaging your appliance, please ensure that you follow recipes in the

instructions and at [www.tefal.co.uk](http://www.tefal.co.uk) or [www.tefal.com.au](http://www.tefal.com.au); make sure that you use the right amount of ingredients.

## Do not

- Do not use the appliance if it or the power cord is damaged or if it has fallen and has visible damage or appears to be working abnormally. If this occurs, the appliance must be sent to an Approved Service Centre.
- Do not use an extension lead. If you nevertheless decide to do so, under your own responsibility, use an extension lead that is in good condition and compliant with the power of the appliance.
- Do not let the power cord dangle.
- Do not unplug the appliance by pulling on the power cord.
- Never move the appliance when it still contains hot food.
- Never operate your appliance when empty.
- Do not switch on the appliance near to flammable materials (blinds, curtains...) or close to an external heat source (gas stove, hot plate etc.).
- Do not store any inflammable products close to or underneath the furniture unit where the appliance is located.
- Never take the appliance apart yourself
- Do not immerse the product in water.
- Do not use any powerful cleaning products (notably soda based strippers), nor brillo pads, nor scourers.
- Do not store your appliance outside. Store it in a dry and well ventilated area.

## Advice/information

- When using the product for the first time, it may release a non-toxic odour. This will not affect use and will disappear rapidly.
- For your safety, this appliance conforms with applicable standards and regulations (Directives on Materials in contact with food, Environment, etc.).
- This appliance is designed for domestic use only and not outdoor. In case of professional use, inappropriate use or failure to comply with the instructions, the manufacturer accepts no responsibility and the guarantee does not apply.
- For your safety, only use the accessories and spare parts designed for your appliance

## Environnement



### Environment protection first!

- ① Your appliance contains valuable materials which can be recovered or recycled.
- ➔ Leave it at a local civic waste collection point.

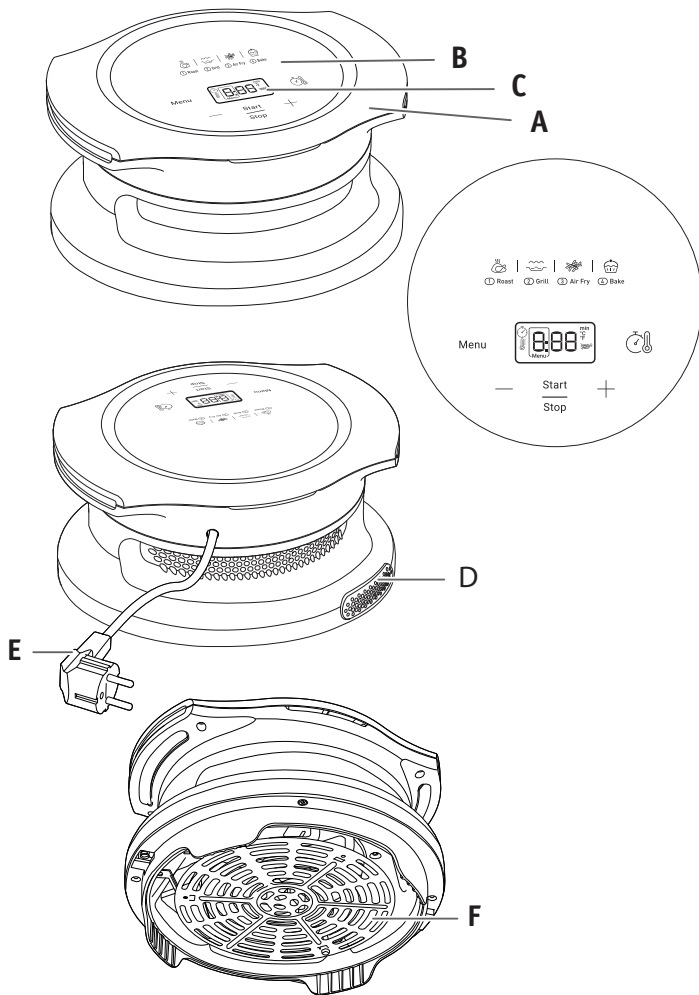

## DESCRIPTION

- A Handles
- B Digital touchscreen panel
- C Time/temperature display
- D Air outlet
- E Cord
- F Grid

## AUTOMATIC COOKING MODES

1. Roast
2. Grill
3. Air fry
4. Bake

## PRECAUTIONS FOR USE

1. This appliance can only be used on Cook4me products, on the Cook4me bowl, positioned in the Cook4me.
2. Never use the appliance on other recipients (plastic, glass, etc.)
3. Check the stability of the appliance above the Cook4me bowl, before starting the cooking cycle.
4. **WARNING!** To avoid any risk of burns, carry the appliance flat while holding the handles.
5. **WARNING!** The Cook4me must not be in operation when using the appliance Extra crisp.
6. At the end of the cooking with Extra Crisp, be sure to remove the appliance before starting a new cooking with Cook4me.

## BEFORE FIRST USE

1. Remove all packaging material.
2. Remove any stickers or labels from the appliance.
3. Thoroughly clean the bowl and the removable grid with hot water, some washing-up liquid and a non-abrasive sponge.
4. Wipe the inside and outside of the appliance with a damp cloth.

## PREPARING FOR USE

1. Place Cook4me on a flat and stable work surface.
2. Never use Extra Crisp lid on your Cook4me without the cooking bowl. Wipe the bottom of the cooking bowl. Make sure that there is no food or liquid residue under the bowl or on the heating plate. Then place the bowl by positioning the handles of the bowl in the notches.
3. **Place Extra Crisp on the Cook4me bowl by aligning the handles of both appliances. Do not place anything on the appliance. The lid of your Cook4me must remain open when using Extra Crisp.**
4. Check the positioning of the cord: it must not be caught under Extra Crisp, nor between Extra Crisp and the open lid of the Cook4me. The appliance will not start.

## USING THE APPLIANCE

Cooking times for the main foods are given in the section 'Cooking Guide'. Recipes on Cook4me app help you get to know the appliance.

1. Connect the power supply cord to an electrical socket.
2. Place the food in the bowl.

**Note:** Never fill the bowl beyond the MAX level mark or exceed the maximum amount indicated in the table (see into section 'Cooking Guide'), as this could affect the quality of the end result.

3. Place Extra Crisp above Cook4me's bowl.

**Caution:** Do not touch the hot parts of the appliance during use. Only touching the screen and holding the appliance by the handles are possible.

4. To begin cooking, you can select between the automatic cooking mode or choose the manual settings.

### a. If choosing manual settings:

- Adjust the temperature (°C) with the (+) and (-) buttons on the digital screen. The thermostat varies from 70-200°C.
- Then set the desired cooking time by pressing the (⌚) button and adjusting the time with the (+) and (-) buttons. The timer can be set for between 0 and 60 minutes.
- Press the Start button to begin cooking with the selected temperature and time settings. Cooking starts. The remaining cooking time will alternate on the screen display.

### b. If choosing automatic cooking mode:

- Press Menu key (Menu) on the screen to select the desired cooking mode (these modes are described in detail in the "Cooking guide" section).
  - Confirm the cooking mode by pressing the Start button. This will launch the cooking process.
  - Cooking starts. The remaining cooking time will alternate on the on-screen display.
5. Some foods require shaking halfway through the cooking time (see section 'Cooking Guide'). To shake the food, remove the appliance from the bowl. To avoid damaging the non-stick coating on the pan, use only wooden or plastic utensils to stir food. Then put Extra crisp back on the bowl and press the Start button (Start/Stop) again to restart cooking.
  6. Once the cooking time has elapsed, the appliance will make a sound and go down in temperature. Remove the appliance from the bowl and place it on a heat-resistant surface.
  7. Check if the food is ready.  
If the food is not ready yet, simply place Extra Crisp back on the bowl and set the timer for a few extra minutes.
  8. When the food is cooked, take out Extra Crisp.

**Caution:** Do not turn Extra Crisp, do not touch the hot grill. Do not turn the bowl, because of any excess hot oil.

After hot air frying, the bowl, Extra Crisp and the food are very hot. Depending on the type of food cooked in the bowl, be careful as steam may escape from the bowl.

Note: after 3 minutes of inactivity, the appliance goes into standby and after 30 minutes of inactivity, the appliance will switch to Sleep mode. Press the button to turn it back on again.

## COOKING GUIDE

The table below helps you to select the basic settings for the food you want to prepare.

**Note:** The cooking times below are only a guide and may vary according to the variety and batch of potatoes used. For other foods the size, shape and brand may affect results. Therefore, you may need to adjust the cooking time slightly.

	Min-max Amount (g)	Approx Time (min)	Temperature (°C)	Cooking mode	Shake*	Extra information
<b>Potatoes &amp; fries</b>						
Frozen chips (10 mm x 10 mm standard thickness)	300-700 g	22-33 min	200°C		Yes	
Homemade French Fries (8 x 8 mm)	300-700 g**	22-33 min	200°C		Yes	Add 1 tbsp of oil
Frozen potato wedges	300-700 g	22-33 min	200°C		Yes	
<b>Meat &amp; Poultry</b>						
Frozen steak	100-400 g	9-17 min	200°C			
Frozen meatballs	400 g	8-12 min	200°C			
Chicken breast fillets (boneless)	100-500 g	12-19 min	200°C			
Chicken (whole)	1200 g	45-50 min	200°C			
<b>Snacks</b>						
Frozen chicken nuggets	100-600 g	7-12 min	200°C			
<b>Baking</b>						
Muffins	4 x 100 g	18-22 min	160°C			Use a baking tin/oven dish**
Cook4me cake mold	700-900 g	50 min	160°C			Use the Cook4me cake mold

\* Shake halfway through cooking.

\*\*place the cake tin/oven dish in the bowl.

**IMPORTANT:** To avoid damaging your appliance, never exceed the maximum quantities of ingredients and liquids indicated in the instruction manual and in the recipes.

When you use mixtures that rise (such as with cake, quiche or muffins) the oven dish should not be filled more than halfway.

Visit the app or [www.tefal.co.uk](http://www.tefal.co.uk) or [www.tefal.com.au](http://www.tefal.com.au) for online recipes.

## TIPS

- Smaller foods usually require a slightly shorter cooking time than larger size foods.
- Shaking foods halfway through the cooking time improves the end result and can help prevent uneven cooking.
- Add some oil to fresh potatoes for a crispy result. After adding a spoon of oil, fry the potatoes within a few minutes.

## MAKING HOME-MADE CHIPS

For the best results, we advise to use frozen chips. If you want to make home-made chips, follow the steps below.

1. Choose a variety of potato recommended for making chips. Peel the potatoes and cut them into equal thickness chips.
2. Soak the potato chips in a bowl of cold water for at least 30 minutes, drain them and dry them with a clean, highly absorbent tea towel. Then pat with paper kitchen towel. The chips must be thoroughly dry before cooking.
3. Pour 1 tablespoon of oil (vegetable, sunflower or olive) in a dry bowl, put the chips on top and mix until they are coated with oil.
4. Remove the chips from the bowl with your fingers or a kitchen utensil so that any excess oil stays behind in the bowl. Place the chips in the bowl.  
**Note: Do not tip the container of oil coated chips directly into the bowl in one go, otherwise excess oil will end up at the bottom of the bowl.**
5. Fry the chips according to the instructions in the section Cooking guide.

## CLEANING

Clean the appliance after every use.

**Do not use metal kitchen utensils or abrasive cleaning materials to clean them, as this may damage the nonstick coating.**

1. Remove the mains plug from the wall socket and let the appliance cool down.
2. Wipe the outside of the appliance with a damp cloth.
3. Clean the grid with hot water, some washing-up liquid and a non-abrasive sponge.  
You can use a degreasing liquid to remove any remaining dirt.  
**Note: The appliance is not dishwasher-safe.**

4. Do not immerse the appliance in water or any other liquid.

## STORAGE

1. Unplug the appliance and let it cool down.
2. Make sure all parts are clean and dry.
3. Store the appliance horizontally, without covering it. Do not turn it over and do not overlay product on it.

## GUARANTEE AND SERVICE

- If your appliance does not start, check that it is correctly positioned on the bowl (the 2 switches must be on, the power cable must not be trapped between the bowl and Extra Crisp).
- If you need service or information or if you have a problem, please visit the Tefal website at [www.tefal.co.uk](http://www.tefal.co.uk) or [www.tefal.com.au](http://www.tefal.com.au) or contact the Tefal Consumer Care Centre in your country. You can find the phone number in the worldwide guarantee leaflet. If there is no Consumer Care Centre in your country, go to your local Tefal dealer.

## TROUBLESHOOTING

If you encounter problems with the appliance, visit [www.tefal.co.uk](http://www.tefal.co.uk) or [www.tefal.com.au](http://www.tefal.com.au) for a list of frequently asked questions or contact the Consumer Care Centre in your country.

**If you have any problems with your appliance or queries call our Customer Relations Team first for expert help and advice:**

**FOR UK (01) 677 4003**

**Helpline: 0345 602 1454**

**GROUPE SEB UK**

**ROI or contact us via our web site: [www.tefal.co.uk](http://www.tefal.co.uk)**

**FOR AUSTRALIA**

**Helpline: 1300307824**

**GROUPE SEB AUSTRALIA**

**PO Box 7535, Silverwater NSW 2128**

**[www.tefal.com.au](http://www.tefal.com.au)**

## TEFAL/T-FAL\* INTERNATIONAL LIMITED GUARANTEE

 : [www.tefal.com](http://www.tefal.com)

*This product is **repairable** by TEFAL/T-FAL\*, during and after the guarantee period.*

Accessories, consumables and end-user replaceable parts can be purchased, if locally available, as described on the TEFAL/T-FAL internet site [www.tefal.com](http://www.tefal.com)

**The Guarantee\*\*** : TEFAL/T-FAL guarantees this product against any manufacturing defect in materials or workmanship during the guarantee period within those countries\*\*\* as stated in the attached country list, starting from the initial date of purchase or delivery date. The international manufacturer's guarantee covers all costs related to restoring the proven defective product so that it conforms to its original specifications, through the repair or replacement of any defective part and the necessary labour. At TEFAL/T-FAL's choice, a replacement product may be provided instead of repairing a defective product.

TEFAL/T-FAL's sole obligation and your exclusive resolution under this guarantee are limited to such repair or replacement.

**Conditions & Exclusions** : TEFAL/T-FAL shall not be obliged to repair or replace any product which is not accompanied by a valid proof of purchase. The product can be taken directly in person or must be adequately packaged and returned, by recorded delivery (or equivalent method of postage), to a TEFAL/T-FAL authorised service centre. Full address details for each country's authorised service centres are listed on TEFAL/T-FAL website ([www.tefal.com](http://www.tefal.com)) or by calling the appropriate consumer Service centre set out in the attached country list. In order to offer the best possible after-sales service and constantly improve customer satisfaction, TEFAL/T-FAL may send a satisfaction survey to all customers who have had their product repaired or exchanged in a TEFAL/T-FAL authorised service centre.

This guarantee applies only for products purchased **and** used for domestic purposes and will not cover any damage which occurs as a result of misuse, negligence, failure to follow TEFAL/T-FAL instructions, or amodification or unauthorised repair of the product, faulty packaging by the owner or mishandling by any carrier. It also does not cover normal wear and tear, maintenance or replacement of consumable parts, or the following:

- using the wrong type of water or consumable
- mechanical damages, overloading
- damage as a result of lightning or power surges
- ingress of water, dust or insects into the product (excluding appliances with features specifically designed for insects)
- accidents including fire, flood, etc
- scaling (any de-scaling must be carried out according to the instructions for use)
- damage to any glass or porcelain ware in the product
- professional or commercial use
- or poor results specifically due to wrong voltage or frequency as stamped on the product ID or specification

**Consumer Statutory Rights** : This international TEFAL/T-FAL guarantee does not affect the Statutory Rights a consumer may have or those **rights that cannot** be excluded or limited, nor rights against the retailer from which the consumer purchased the product. This guarantee gives a consumer specific legal rights, and the consumer may also have other legal rights which vary from State to State or Country to Country. The consumer may assert any such rights at his sole discretion.

\*\*\*Where a product purchased in a listed country and then used in another listed country, the international TEFAL/T-FAL guarantee duration is the one in the country of usage, even if the product was purchased in a listed country with different guarantee duration. The repair process may require a longer time if the product is not locally sold by TEFAL/T-FAL. If the product is not repairable in the new country, the international TEFAL/T-FAL guarantee is limited to a replacement by a similar or alternative product at similar cost, **where possible**.

\*TEFAL household appliances appear under the T-FAL brand in some territories like America and Japan. TEFAL/T-FAL are registered trademarks of Groupe SEB.

Please keep this document for your reference should you wish to make a claim under the guarantee.

**\*\*For Australia only:**

Our goods come with guarantees that cannot be excluded under the Australian Consumer Law. You are entitled to a replacement or refund **for a major failure and compensation for** any other reasonably foreseeable loss or damage. You are also entitled to have the goods repaired or replaced if the goods fail to be of acceptable quality and the failure does not amount to a major failure.

**\*\*For India only:** The guarantee length depends on the product and the State in India. Full guarantee terms must be checked at the point of sale. Products purchased outside and used in India benefit from a 2 year guarantee.

The guarantee covers exclusively the repair of a defective product, but at TEFAL's choice, a replacement product may be provided instead of repairing a defective product. It is **mandatory** that the consumer, to have his product repaired, has to log a service request on the dedicated Smartphone application TEFAL SERVICE APP or by calling TEFAL Consumer Care Center at **1860-200-1232, Opening hours Mon-Sat 09 AM to 06 PM**. Products returned by Post will not be covered by the guarantee. As a proof of purchase consumer needs to provide both this stamped guarantee card and cash memo.

