

Tefal®

EN



Oleoclean Compact

www.tefal.co.uk

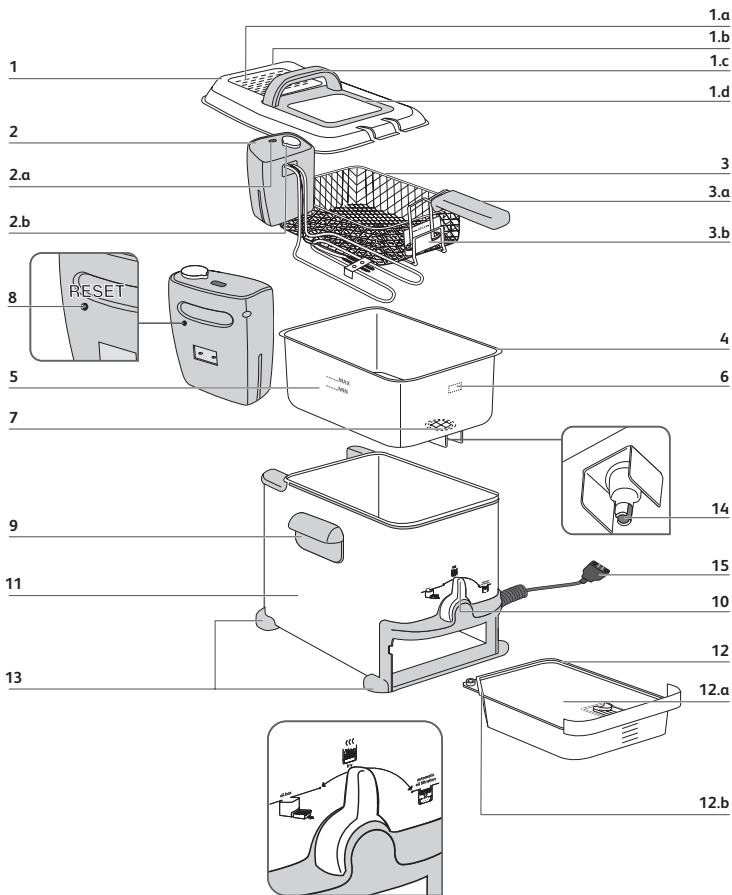

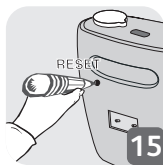
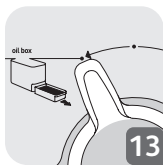
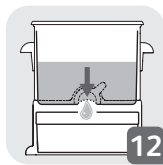
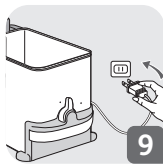
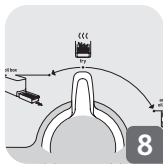
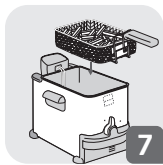
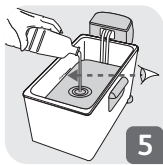
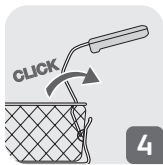
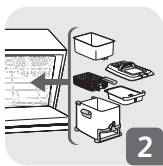

SAFETY INSTRUCTIONS

IMPORTANT SAFEGUARDS

- This appliance is intended to be used in household only. It is not intended to be used in the following applications, and the guarantee will not apply for:
 - staff kitchen areas in shops, offices and other working environments;
 - farm houses;
 - by clients in hotels, motels and other residential type environments;
 - bed and breakfast type environments.
- This appliance is not intended for use by persons (including children) with reduced physical, sensory or mental capabilities, or lack of experience and knowledge, unless they have been given supervision or instruction concerning use of the appliance by a person responsible for their safety.
- Children must be supervised to ensure that they do not play with the appliance.
- This appliance shall not be used by children from 0 year to 8 years. This appliance can be used by children aged from 8 years and above if they are continuously supervised. This appliance can be used by people with reduced physical, sensory or mental capabilities or lack of experience and knowledge if they have been given supervision or instruction concerning use of the appliance in a safe way and understand the hazards involved.

Keep the appliance and its cord out of reach of children aged less than 8 years. Cleaning and user maintenance shall not be made by children.

- Cooking appliances should be positioned in a stable situation with the handles (if any) positioned to avoid spillage of the hot liquids.
- This appliance is not intended to be operated by means of an external timer or a separate remote-control system.
- If the power supply cord is damaged, it must be replaced by the manufacturer, an authorised service centre or a similarly qualified person in order to avoid any danger.
-  The temperature of accessible surfaces may be high when the appliance is operating. Do not touch the hot surfaces of the appliance.
- Keep the appliance and its cord out of reach of children less than 8 years.
- Clean the lid, bowl, body and basket with a cloth and some water or in a dishwasher (depending on the model). Clean the electric unit separately with a damp cloth. Please refer to the «Cleaning» section of the instructions for use.
- Never immerse the appliance or the electrical control unit in water!
- The appliance can be used up to an altitude of 4000 m.

Do

- **CAUTION: the safety precautions are part of the appliance. Read them carefully before using your new appliance for the first time. Keep them in a place where you can find and refer to them later on.**
- Read and follow the instructions for use. Keep them safe.
- Check that the power supply voltage corresponds to that shown on the appliance (alternating current).
- Given the diverse standards in effect, if the appliance is used in a country other than that in which it is purchased, have it checked by an approved Service Centre.
- Remove all packaging materials and any promotional labels or stickers from your deep fryer before use. Be sure to also remove any materials from underneath the removable bowl (depending on model).
- Do not use the appliance if the appliance or the cord is damaged, if the appliance has fallen or shows visible damage or does not work properly. In the event of the above, the appliance must be sent to an approved Service Centre. Do not take the appliance apart yourself.
- Always plug the appliance into an earthed socket.
- Always unplug the appliance: immediately after use, when moving it, prior to any cleaning or maintenance.
- Use a flat, stable, heat-resistant surface, away from any water splashes.

Do not

- Do not use an extension lead. If you accept liability for doing so, only use an extension lead which is in good condition, has an earthed plug and is suited to the power of the appliance.
- Do not leave the cord hanging. The power cord must never be in close proximity to or in contact with the hot parts of your appliance, close to a source of heat or rest on sharp edges.
- Do not unplug the appliance by pulling on the cord.
- Never leave the appliance unattended when in use.
- Do not switch on the appliance near to flammable materials (blinds, curtains...). or close to an external heat source (gas stove, hot plate etc.).
- Do not move the appliance when it is full of liquids or hot food.
- If you have a removable bowl, never take it out when the fryer is switched on.
- Do not store your deep fryer outside. Store it in a dry and well ventilated area.
- Never plug in the deep fryer without oil or fat inside. The oil level must

always be between the min and max markers.

- Never put solid fat directly into the deep fryer bowl or fryer basket as this will lead to deterioration of the appliance.
- Do not mix different types of oil. Never add water to the oil or fat.
- Do not overfill the basket, never exceed the maximum capacity.

Advice/information

- For your safety, this appliance conforms to applicable standards and regulations : (Low Voltage Directive, Electromagnetic compatibility, Materials in contact with food, Environment.)
- This appliance is designed for domestic use only and not outdoor. In case of professional use, inappropriate use or failure to comply with the instructions, the manufacturer accepts no responsibility and the guarantee does not apply.
- For your own safety, use only accessories and spare parts which are suitable for your appliance.
- For models with removable cord, only the original power cord can be used.
- In the event of fire, never try to extinguish the flames with water. Close the lid. Unplug the appliance. Smother the flames with a damp cloth.
- Before discarding your appliance you should remove the battery from the timer and dispose of it at a local civic waste collection centre (according to model).
- It is **essential** that you wait until the oil has cooled down before storing the fryer.
- If you use solid vegetable fat, cut it into pieces and melt it over a slow heat in a separate pan beforehand, then slowly pour it into the deep fryer bowl.
- If you have a removable anti-odour filter, change it after every 10 - 15 uses (foam filter) or after 30 - 40 uses (cartridge with saturation indicator), or 80 uses (carbon filter). Some models are equipped with a permanent metallic filter, which does not need to be changed.
- Use the basket for chips.
- Control the cooking: Do not eat burnt food.
- Clean your oil after every use to avoid burnt crumbs and change it regularly.
- Eat a balanced and varied diet which includes plenty of fruits and vegetables.
- Store your fresh potatoes in a room above 8°C.
- For best results and fast cooking, we recommend that you limit the quantity of chips to 1/2 basket per frying.
- For a larger quantities of food or potatoes, the temperature drops very fast just after having lowered the basket. This lowers the oil temperature considerably and it never reaches above 175°C, even if the thermostat is set at 190°C.

DESCRIPTION

- | | |
|--|---------------------------------|
| 1 Lid | 5 MIN and MAX oil level markers |
| a Permanent filter | 6 Basket high position |
| b Filter cover | 7 Fixed oil filter grid |
| c Handle | 8 Reset function |
| d Viewing window | 9 Safety carrying handles |
| 2 Removable control unit and heating element | 10 Oil box control button |
| a Temperature indicator light | 11 Housing |
| b adjustable thermostat | 12 Oil box |
| 3 Frying basket | a Lid |
| a Handle | b Cap |
| b MAX food level marker | 13 Feet |
| 4 Removable bowl | 14 Valve |
| | 15 Power cord |

Filtration, drainage and automatic storage of oil/fat

- Your fryer is fitted with an exclusive and patented system for filtration and automatic drainage, suitable for most types of oils and fat used for cooking.
- The **drainage** of oil is completely automatic and safe.
- The **automatic patented** filtration system ensures your oil/fat stays clean and lasts longer for healthier frying.
- The **Oil box container** enables you to store your oil and keep it until you want to use it next and to avoid any transfer of flavours.

Ultra easy cleaning

- Your fryer is easy to handle and to dismantle – **fig. 1**.
- All the parts (except the control unit) are dishwasher safe – **fig. 2**.
- Thanks to the patented automatic filtration and oil storage system, your fryer can go into the dishwasher after each use, making it clean as new after each use.

Using the Oil box container control button

- The Oil box control button has 3 positions.

Fry Position : to fry.

Automatic Oil Filtration Position : to drain and filter the oil into the oil box.

Oil box Position : to allow for removal of the oil box container.

Before using for the first time

- The fryer can be completely dismantled – **fig. 1**.
Remove the lid. Remove the frying basket, the control unit and the bowl. Remove the oil box by positioning the Oil box control button on the Oil box position.
- Clean the lid, the bowl, the housing, the frying basket – **fig. 2** and the Oil box with washing-up-liquid or put them in the dishwasher. Clean the control unit and the heating element with a damp cloth. Dry thoroughly.
- After cleaning, press on the valve under the fryer to release any water in the bowl.
- Place the bowl and the heating element in position.
- Place the Oil box control button on the Oil box position and insert the empty Oil box into the fryer.
- Completely unfold the basket handle; a “click” indicates that it is correctly positioned – **fig. 4**.

– Do not immerse the control unit with the heating element in water or any other liquid – **fig. 3**.
– Check that the valve has gone back to its original position.
– Make sure that the control unit is correctly positioned otherwise the fryer cannot function.

Filling the bowl

- Fill the bowl with oil – **fig. 5**.
- Never exceed the maximum level indicated in the bowl – **fig. 5**.

	Oil	Solid Vegetable fat (not recommended)
Min.	9 cups/1,8L	3,61lbs / 1640 g
Max.	10 cups/ 2L	4,01 lbs/ 1820 g

- For best results we recommend using a good quality blended vegetable oil. If using sunflower oil ensure the oil is changed every 5 uses. Oils which should NOT be used under any circumstances and may cause overflowing/smoking/risk of fire are: ground nut oil, soya oil, olive oil, lard or drippings.

- **If you use solid vegetable fat, cut it into small pieces and melt it in a separate pan – fig. 6.** Pour the melted fat into the fryer bowl. Never melt solid fat on the heating element or in the frying basket.

- Do not mix different types of oil or fat as this may cause the oil to overflow.
- The oil/fat level must always be between the min. and max. markers, stamped inside the bowl. Check this each time prior to cooking and add some of the same type of oil if necessary.

Frying process

- Ensure that the oil box control button is set to the Fry position – **fig. 8.**
- After the bowl has been filled with oil, plug in the fryer without the frying basket – **fig. 9** and the temperature indicator light will switch on. Turn the adjustable thermostat to the desired temperature (see cooking tables) – **fig. 10.**
- Put the lid on
- The fryer will now start to heat the oil.
- Note : the temperature indicator light will switch off when the desired temperature is reached.

Loading the basket

- **Remove excess water, ice or frost from food.**
- Place the basket on a work surface and fill the basket with food (see the cooking tables page 12) – **fig. 7.** Do not overfill the basket. Reduce the quantities for frozen foods.
- **Cooking tips :** Cut food into similar-sized pieces so that they cook evenly. Avoid using pieces that are too thick. For crispier frozen fries, wash them in cold water and dry them carefully. Not all frozen foods are ready to use without thawing first, check the manufacturer's instructions.

IMPORTANT

No matter what the recipe, food must be dried thoroughly before frying. This will prevent the oil from overflowing and extend the life of the oil. During cooking, it is normal for the temperature light to go on and off. Do not touch the fryer when it is in use as it will be extremely hot and can cause severe burns. Steam coming from the filter is also extremely hot.

Lowering the basket

- After the temperature indicator light has gone out, remove the lid, place and lower the basket slowly into the oil . Plunging the basket too rapidly in the oil may cause it to overflow.
- Wait for 1 minute before putting the lid on.

At the end of cooking time

- Frying is complete when the cooking time has elapsed and food is the desired colour and texture.
- Move the thermostat down to the lowest setting.
- Remove the lid using the lid handle carefully to avoid any oil splashes, never let condensation drops from the lid fall into the oil.
- Place the basket on the edge of the bowl with basket hanging clips.
- Allow the excess oil to drain from the food.
- Remove the basket. Serve the food.
- Replace the lid when the fryer is not in use.
- To use a second time, correct the oil level if necessary and plug in the fryer. The temperature indicator light will go on. Set the thermostat to the desired position – **fig. 11**.
- To avoid any risk of burns, never put your hands above the filtration zone.

Switching off the deep fryer

- When you have finished frying, move the thermostat down to the lowest setting, then unplug the deep fryer.
- Allow the oil to cool completely in the fryer (approx. 2 hours).
- Move the fryer using the carrying handles.

Table of cooking times

- The cooking times and temperatures are a guide only, they may vary depending on the size of the food, the amount of the food, individual preferences and the voltage.
- It is important to fry hand made chips twice for best results and to prevent the oil from overflowing:
 - first frying at 320°F / 160°C
 - second frying at 374°F / 190°C.
- After the first frying, set the adjustable thermostat to 374 F/190 C and wait for the temperature indicator light to go out before lowering the chips into the oil for the second frying.

- When cooking battered food and doughnuts, remove the wire basket to prevent food from sticking to it and use tongs to slowly lower the food into the hot oil. Gradually place the food into the hot oil, submerging it an inch at a time to prevent it from sinking straight away.

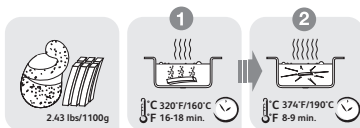

Fresh food	Quantity	Temperature	Cooking time
Chips (MAX capacity)	2.43 lbs/1100 g	① 320°F / 160°C	16-18 min
		② 374°F / 190°C	8-9 min
Chips (recommended capacity)	1.32 lbs/600 g	374°F / 190°C	13-15 min
Chicken legs	4	356°F / 180°C	16-18 min
Apple fritters	6	338°F / 170°C	6-8 min
Breaded mushrooms	0,88 lb/400 g	302°F / 150°C	10-12 min
Breaded fish fillets	0,88 lb/400 g	320°F / 160°C	6-7 min
Frozen food	Quantity	Temperature	Cooking time
Chips (MAX safety capacity)	1,21 lbs/550 g	374°F / 190°C	11-13 min
Chicken nuggets	1,76 lbs/800 g	374°F / 190°C	8-10 min
Breaded fish fillets	0,77 lb/350 g	374°F / 190°C	6-7 min
Frozen scampi	15	374°F / 190°C	4-5 min

We recommend that you:

- clean your oil after each use to avoid burnt crumbs
- change your oil regularly.

CLEANING AND MAINTENANCE

- For your safety, the appliance automatically drains all kinds of oils (or solid fats) when it is cool enough (approximately 2 hours after the last cooking).

IMPORTANT

Make sure that the oil container is empty before draining the fryer.

- When finished cooking, turn the Oil box control lever on the Automatic oil filtration position – **fig.12**.
- Once the filtration is finished, you can store the container :

- In the appliance: Turn the Oil box control lever on Fry position. The appliance must be carried and transported flat.
- Out of the appliance : Turn the Oil box control lever to the Oil box position and then remove the container – **fig.13**.
- Transport it with care.
- **IMPORTANT:** To carry your deep fryer use the handles. Do not use the vents at the bottom of the housing.

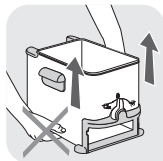
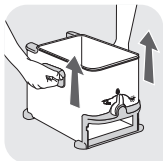

- To re-use the oil, remove the container with care. Unscrew the oil box cap and empty the oil in the fryer bowl.
- For solid fat (not recommended), remove the lid from the container. Turn the container over and press it to loosen the fat. Cut it into pieces and melt it in a separate pan. Then, pour it into the bowl.
- Insert the empty container in the fryer, with its lid and cap. Place the Oil box control button on the Fry position.
- **100% dishwasher safe (except the control unit)**
- The lid, bowl, housing, frying basket and the Oil box are dishwasher safe.
- Store oil in a cool, dry place at a temperature no higher than room temperature.
- Clean the control unit separately with a damp cloth.
- The oil filter grid located in the removable bowl is fixed. Do not try to dismantle it.

- Make sure that the oil container is empty before draining the fryer.
- Carry the container with both hands. Store it in a cool dry place away from the light and especially from humidity.
- Never put the Oil box in the microwave oven.
- Do not pour used oil in the sink. Leave it to cool, and throw it away with household waste-according to the local community regulations.
- Before filling the fryer bowl, always check to ensure the valve under the fryer is in the right position.

IMPORTANT

In order to avoid water being added to the oil :

- Please respect carefully the safety and usage recommendations contained in the Instructions For Use.
- Use your fryer away from water splashes.
- Dry the food thoroughly before cooking.
- Make sure that the filter is clean, so as to always allow the free circulation of the steam.
- When you open the lid, be careful not to let the condensation drops fall into the oil.
- Ensure that the oil box is clean and dry before draining and filtering the oil.(*)
- Never store the oil box full of oil in the refrigerator.(*)
- Always store the oil box in the horizontal position, with lid closed, in a dry place.(*)
- After each cleaning of the bowl, press on the valve of the oil filtration system located under the bowl.(*)
- Dry all the cleaned parts thoroughly before reassembling and storing the fryer.
- Never store your deep fryer outside. Choose a dry and well-ventilated place.

RESET FUNCTION

- Your appliance is equipped with an overheating security feature located in the back of the control unit.
- If you use your fryer without oil the safety cut-off is activated and the appliance will shut off automatically.
- In this case, unplug the appliance and let it cool (about 30 minutes).
- After the bowl has been filled with oil, plug the appliance in. Then press the safety cut-off RESET button with a toothpick or similar non-metallic object – fig.15.
- If the problem with the safety cut-off persists, please contact our Helpline (see details on page 18).

Problems	Possible causes	Solutions
The fryer is not heating	The appliance is not plugged in.	Plug in the appliance.
	The Reset function has activated. The indicator light does not come	Press the “reset” button, which is located at the back of the fryer. If the problem persists, please contact our Consumer Service Department.
The frying oil overflows	The MAX marker for filling the bowl has been exceeded.	Check the oil level (MAX), and remove the excess.
	The MAX marker for filling the frying basket has been exceeded.	Check the MAX level of the frying basket, and remove the excess.
	Food is wet or contains too much water (frozen food).	Remove any ice and dry the food thoroughly. Lower the basket slowly.
	Different types of oil/fat have been mixed.	Empty and clean the bowl. Refill the bowl with one type of oil.
The food does not become golden, and remains soft	The food is too thick and contains too much water.	Experiment by lengthening the cooking time or cut food into thinner pieces.
	Too much food being cooked at the same time and the cooking oil is not at the right temperature.	Fry food in small quantities (especially when frozen).
	The temperature of the frying oil may not be high enough: the temperature is set incorrectly.	Set to the recommended temperature.
The Chips stick together	The Chips stick together.	Wash potatoes well and dry them thoroughly.

Problems	Possible causes	Solutions
The bowl does not drain	The oil is still too hot.	Wait for the temperature to go down (approximately 2 hours).
	The Oil box control button is not on the Automatic Oil Filtration position.	Turn the Oil box control button on the Automatic Oil Filtration position.
	The filter grid is blocked or clogged.	Empty the oil into a container and clean the filter grid with soap and water and a non-metallic brush. Press on the valve under the fryer to let out water and crumbs.
	The fat has is solidified.	Allow the fryer to heat (4 to 5 minutes).
Oil leaks	The max (2 l) fill mark for the bowl has been exceeded.	Do not exceed the oil level (2 l). Clean the fryer before any use.
	There is some oil left in the container or it is full.	Turn the Oil box control button on the Oil box position, pull out the container and drain it.
Emits unpleasant smells	The oil has deteriorated.	Use new oil.
	The oil is unsuitable.	Use a good quality blended vegetable oil.
Noise during frying	If you hear slight popping sounds when using your appliance, it means that there is too much water in the frying oil. The danger comes from water being found in the oil box inside the removable bowl (as a result of the filtering process)	Change the oil.
Other problems	The temperature indicator light does not come on.	Press the "reset" button, which is located at the back of the fryer. If the problem persist, please contact our Consumer Service Department.

TEFAL/T-FAL * INTERNATIONAL LIMITED GUARANTEE

EN

 : www.tefal.com

This product is repairable by TEFAL/T-FAL*, during and after the guarantee period.

Accessories, consumables and end-user replaceable parts can be purchased, if locally available, as described on the TEFAL/T-FAL internet site www.tefal.com

The Guarantee**

TEFAL/T-FAL guarantees this product against any manufacturing defect in materials or workmanship during the guarantee period within those countries*** as stated in the attached country list, starting from the initial date of purchase or delivery date. The international manufacturer's guarantee covers all costs related to restoring the proven defective product so that it conforms to its original specifications, through the repair or replacement of any defective part and the necessary labour. At TEFAL/T-FAL's choice, an equivalent or superior replacement product may be provided instead of repairing a defective product. TEFAL/T-FAL's sole obligation and your exclusive resolution under this guarantee are limited to such repair or replacement.

Conditions & Exclusions

TEFAL/T-FAL shall not be obliged to repair or replace any product which is not accompanied by a valid proof of purchase. The product can be taken directly in person or must be adequately packaged and returned, by recorded delivery (or equivalent method of postage), to a TEFAL/T-FAL authorised service centre. Full address details for each country's authorised service centres are listed on TEFAL/T-FAL website (www.tefal.com) or by calling the appropriate consumer Service centre set out in the attached country list. In order to offer the best possible after-sales service and constantly improve customer satisfaction, TEFAL/T-FAL may send a satisfaction survey to all customers who have had their product repaired or exchanged in a TEFAL/T-FAL authorised service centre. This guarantee applies only for products purchased and used for domestic purposes and will not cover any damage which occurs as a result of misuse, negligence, failure to follow TEFAL/T-FAL instructions, or a modification or unauthorised repair of the product, faulty packaging by the owner or mishandling by any carrier. It also does not cover normal wear and tear, maintenance or replacement of consumable parts, or the following:

- using the wrong type of water or consumable
- mechanical damages, overloading
- ingress of water, dust or insects into the product (excluding appliances with features specifically designed for insects)
- damage as a result of lightning or power surges
- scaling (any de-scaling must be carried out according to the instructions for use)
- accidents including fire, flood, etc
- damage to any glass or porcelain ware in the product
- professional or commercial use
- damages or poor results specifically due to wrong voltage or frequency as stamped on the product ID or specification

Consumer Statutory Rights

This international TEFAL/T-FAL guarantee does not affect the Statutory Rights a consumer may have or those rights that cannot be excluded or limited, nor rights against the retailer from which the consumer purchased the product. This guarantee gives a consumer specific legal rights, and the consumer may also have other legal rights which vary from State to State or Country to Country. The consumer may assert any such rights at his sole discretion.

***Where a product purchased in a listed country and then used in another listed country, the international TEFAL/T-FAL guarantee duration is the period for the country of usage, even if the product was purchased in a listed country with a longer guarantee duration. The repair process may require a longer time if the product is not locally sold by TEFAL/T-FAL in the country of usage. If the product is not repairable in the new country of usage, the international TEFAL/T-FAL guarantee is limited to a replacement by a similar or alternative product at similar cost, where possible.

*TEFAL household appliances appear under the T-FAL brand in some territories like America and Japan. TEFAL/T-FAL are registered trademarks of Groupe SEB.

Please keep this document for your reference should you wish to make a claim under the guarantee.

****For Australia only:**

Our goods come with guarantees that cannot be excluded under the Australian Consumer Law. You are entitled to a replacement or refund for a major failure and compensation for any other reasonably foreseeable loss or damage. You are also entitled to have the goods repaired or replaced if the goods fail to be of acceptable quality and the failure does not amount to a major failure.

****For India only:** Your Tefal product is guaranteed for 2 years. The guarantee covers exclusively the repair of a defective product, but at TEFAL's choice, a replacement product may be provided instead of repairing a defective product. It is mandatory that the consumer, to have his product repaired, has to log a service request on the dedicated Smartphone application TEFAL SERVICE APP or by calling TEFAL Consumer Care Center at **1860-200-1232, Opening hours Mon-Sat 09 AM to 06 PM**. Products returned by Post will not be covered by the guarantee. As a proof of purchase consumer needs to provide both this stamped guarantee card and cash memo.

