

Tefal

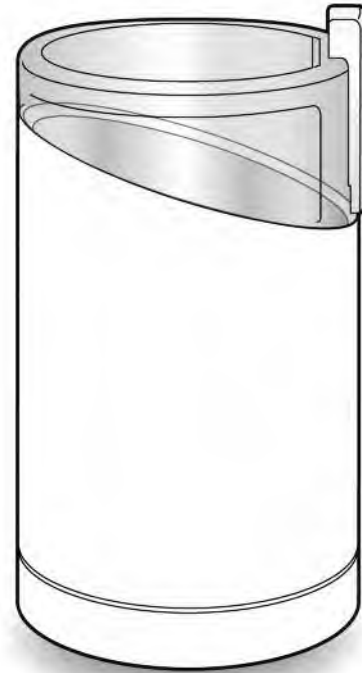

EN

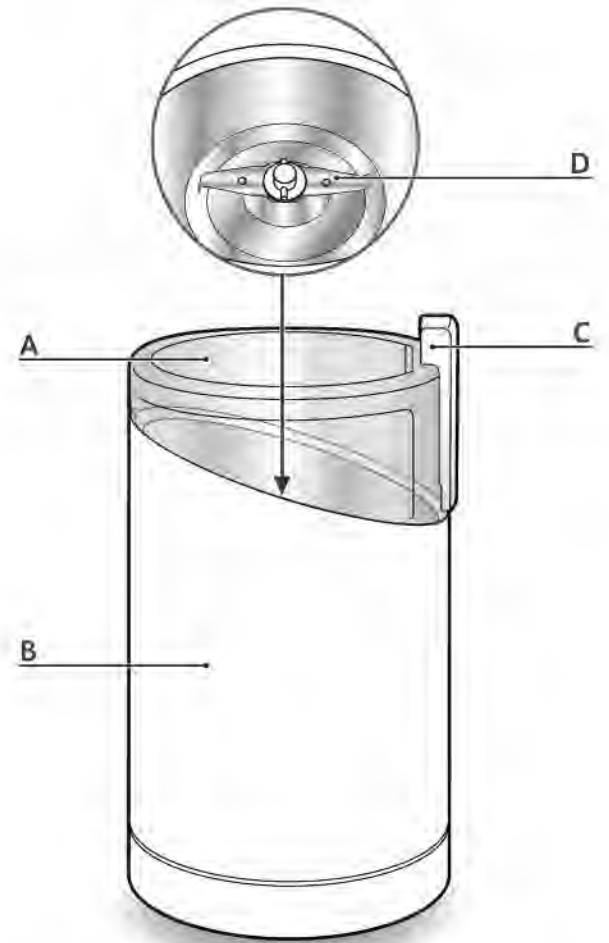



fig.1



fig.2



TEFAL / T-FAL INTERNATIONAL GUARANTEE

Date of purchase: / Date d'achat / Fecha de compra /
Data da compra / Data d'acquisto / Kaufdatum / Aankoopdatum / Købsdato / Inköpsdatum /
Kjøpsdato / Ostoupání / Data zakupu / Data vânzării / [sigijimo data/ Ostukupäev / Datum nákupa /
Sorozatsszám / Dátum nákupu / Pirkuma datums / Datum Kupovine / Datum kupnje / Data
cumpărării / Datum nákupu / Tarikh pembelian / Tanggal pembelian / Ngày mua hàng/ Satın alma
tarih / Дата продажи / Дата продаж / Дата на закупване / Датум на купување / Сатылган
мерзімі / Ημερομηνία αγοράς/ Ψάδωνη όρη /วันที่ซื้อ / 購買日期/購入日/구입일자 / تاريخ
الشراء / خرید/ تاریخ الشراء

Product reference: / Référence du produit / Referencia del
producto / Nome do produto / tipo de prodotto / Typnummer des Gerätes / Artikelnummer van het
apparaat / Referencenummer / Produktreferens / Artikelnummer / Tuotenumero / referenca
produktu / Model / Gaminio numeris / Toote viitenumber / Tip aparata / Vásárlás kelte / Typ
výrobku / Produkta atsauces numurs / Model proizvoda / Oznaka proizvoda / Cod produs / Produk
rijukan / Referens produkt / Mã sản phẩm/ Ürün kodu / Модель / Модель / Model на уреда /
Model / Кодикос προϊόντος / Όηηη / รุ่นผลิตภัณฑ์ / 產品模型 / 製品レファレンス番号 / 제품명/
مرجع كامل محصول / مرجع المنتج الكامل

Retailer name & address: / Nom et adresse du vendeur / Nombre y dirección del minorista / Nome e endereço do revendedor
/ Nome e indirizzo del negozio / Name und Anschrift des Händlers / Naam en adres van de dealer /
Forhandler navn & adresse / Återförsäljarens namn och adress / Forhandler navn og adresse /
Jälleenmyyjän nimi ja osoite / nazwa i adres sprzedawcy / Numele și adresa vânzătorului /
Parduotuvės pavadinimas ir adresas / Māija kaupļus ja adress / Naziv in naslov trgovine /
Tipusszám / Názov a adresa predajcu / Veikala nosaukums un adrese / Naziv i adresa maloprodaje /
Naziv i adresa prodavca / Naziv i adresa prodajnog mjesta / Nume și adresă vânzător / Název a
adresa prodejece / Nama dan alamat peruncit / Nama Toko Penjual dan alamat / Tên và địa chỉ cửa
hàng bán/ Satici firmann adı ve adresi / Название и адрес продавца / Назва і адреса продавця /
Търговки обект / Назив и адреса на продавницата / Сатушының аты және мекен-жайы /
Επινομητα και διεύθυνση καταστήματος / Ψάδωνηη υπεύθυνηη η ηυαυηηη /
ชื่อและที่อยู่ของห้างร้านที่ซื้อ / 零售商的店名和地址/販売店の名前、住所/소매점 이름과 주소/
تام وادرس خرده فروش / اسم بائع التجزئة و عنوانه

Distributor stamp / Cachet distributeur / Sello del distribuidor /
Carimbo do revendedor / Timbro del negozio / Händlerstempel / Stempel van de dealer /
Forhandler stempel / Återförsäljarens stämpel / Forhandler stempel / Jälleenmyyjän leima / pieczęć
sprzedawcy / Štampila vânzătorului / Antspaudas / Tempel / Žig trgovine / Eladó neve, címe/
Razitko predajcu / Zimogs / Pečat maloprodaje/ Pečat prodavca / Pečat prodajnog mjesta / Štampila
vânzătorului/ Razitko prodejece/ Cap peruncit / Cap dari Toko Penjual / Cửa hàng bán đồng dấu/
Satici Firmann Kaşesi / Печать продавца / Печатка продавця / Печат на търговския обект /
Печат на продавницата / Сатушының мөрі / Σφραγίδα καταστήματος / Ψάδωνηη η ηηηηηηη /
ตราประทับของห้างร้านที่ซื้อ / 零售商的蓋印/販売店印/소매점 직인/ختم بائع التجزئة/ مهر خرده
فروش

Description

A – Lid

B – Motor unit

C – On/Off button

D – Blades

Safety instructions

- Please read the following instructions carefully before using your appliance for the first time and follow them strictly. The manufacturer cannot be held liable for any damage caused by the failure to follow this user guide.
- This product has been designed for domestic use only. Any commercial use, inappropriate use or failure to comply with the instructions, the manufacturer accepts no responsibility and the guarantee will not apply.
- Check that the power rating of your appliance corresponds to your electrical supply.

Any incorrect connection invalidates the guarantee.

- Your appliance is for domestic use only. In the event of any commercial use, inappropriate use or failure to comply with the instructions, the manufacturer accepts no responsibility and the guarantee will not apply.
- The appliance must be unplugged when no longer in use, during cleaning or in the event of a power cut. Do not unplug it by pulling on the supply cord.
- Do not use your appliance if it does not operate correctly, if it has been damaged or if the supply cord is damaged; the supply cord must be replaced by the manufacturer or an approved service centre or a similarly qualified person in order to avoid any hazard.
- Any servicing other than cleaning and user maintenance must be performed by an approved service centre.
- Never immerse the appliance, supply cord or plug in water or other liquid.
- Do not leave the supply cord within reach of children. Keep it away from hot parts of the appliance, sources of heat or sharp objects, including the grinder blades.
- Use only accessories and parts supplied with your appliance. The manufacturer cannot accept responsibility if this is not the case.

Before first use

Note :

Be very careful when you handle the blades to avoid injury.

- Before using your appliance for the first time, clean all the accessories in warm soapy water (except for the motor unit (B): to clean the motor unit, refer to the section "Cleaning").
- Rinse and dry the lid thoroughly (A).
- **Make sure you have removed all the packaging materials before using your coffee grinder.**

Use

- Place the motor unit (B) on a perfectly flat and stable worktop and plug in the appliance.
- Fill the grinding chamber (Fig. 1) with coffee beans.
- Place the lid (A) on the motor unit (B). To start grinding, press the On/Off button (C) (Fig. 2). The grinder will operate as long as you hold the button (C).
- You can grind up to 75 g of coffee, spices, seeds or dry fruits.
- Do not run your appliance continuously for more than 20 seconds at a time. Let it cool for 1 minute before pressing the On/Off button.

Note:

Wait until the blades have stopped completely before removing the lid (A), and then unplug the coffee grinder.

Cleaning

- Unplug the appliance before cleaning it.
- Wipe the motor unit (B) with a damp cloth and dry it thoroughly.
- Do not use scouring pads, acetone, alcohol, etc. to clean your coffee grinder.
- **Never immerse the motor unit under running water.**
- Use a soft brush to clean the grinding chamber.
- **The blades are very sharp; handle them very cautiously.**

What to do if your appliance does not work ?

- First check that the supply cord and plug are connected properly and are in good condition. If this is the case, make sure that the lid (A) is correctly in place on the motor unit (B).

Your appliance still does not work ?

- Contact an approved service centre (you will find the list of service centres in the booklet supplied).

Recycling end-of-life electric or electronic products

Your appliance is expected to last for many years. However, when the time comes to replace it, do not throw it in the bin or in a dump, but take it to the recycling centre in your town (or to a waste reception centre where applicable).

Think of the environment !



- **i** Your appliance contains valuable materials which can be recovered or recycled.
- **➡** Leave it at a local civic waste collection point.

TEFAL / T-FAL* INTERNATIONAL LIMITED GUARANTEE



www.tefal.com / www.t-fal.com

This product is **repairable** by TEFAL / T-FAL, during and after the **guarantee period**.

The Guarantee

This product is guaranteed by TEFAL / T-FAL (company address and details included in the country list of the TEFAL / T-FAL International Guarantee) against any manufacturing defect in materials or workmanship during the guarantee period within those countries as stated in the country list on the last page of the user manual, starting from the initial date of purchase.

The international manufacturer's guarantee by TEFAL/T-FAL is an extra benefit which does not affect consumer's Statutory Rights.

The international manufacturer's guarantee covers all costs related to restoring the proven defective product so that it conforms to its original specifications, through the repair or replacement of any defective part and the necessary labour. At TEFAL/T-FAL's choice, a replacement product may be provided instead of repairing a defective product. TEFAL/T-FAL's sole obligation and your exclusive resolution under this guarantee are limited to such repair or replacement.

Conditions & Exclusions

The international TEFAL/T-FAL guarantee only applies within the guarantee period and for those countries listed in the Country List attached and is valid only on presentation of a proof of purchase. The product can be taken directly in person to an authorised service centre or must be adequately packaged and returned, by recorded delivery (or equivalent method of postage), to a TEFAL/T-FAL authorised service centre. Full address details for each country's authorised service centre are listed on TEFAL/T-FAL website (www.tefal.com / www.t-fal.com) or by calling the appropriate telephone number as set out in the Country List to request the appropriate postal address.

TEFAL/T-FAL shall not be obliged to repair or replace any product which is not accompanied by a valid proof of purchase.

This guarantee will not cover any damage which could occur as a result of misuse, negligence, failure to follow TEFAL/T-FAL instructions, use on current or voltage other than as stamped on the product, or a modification or unauthorised repair of the product. It also does not cover normal tear and wear, maintenance or replacement of consumable parts, or the following:

- using the wrong type of water
- scaling (any de-scaling must be carried out according to the instructions for use);
- ingress of water, dust or insects into the product;
- mechanical damages, overloading
- damages or bad results due to wrong voltage or frequency
- accidents including fire, flood, thunderbolt etc
- professional or commercial use
- damage to any glass or porcelain ware in the product
- replacement of consumables

This guarantee does not apply to any product that has been tampered with, or to damages incurred through improper use and care, faulty packaging by the owner or mishandling by any carrier.

The international TEFAL/T-FAL guarantee applies only for products purchased in one of the countries listed, and used for domestic purposes only in one of the countries listed on the Country List. Where a product purchased in one listed country and then used in another listed country:

- a) The international TEFAL/T-FAL guarantee duration is the one in the country of usage of the product, even if the product was purchased in another listed country with different guarantee duration.
- b) The international TEFAL/T-FAL guarantee does not apply in case of non conformity of the purchased product with the local standards, such as voltage, frequency, power plugs, or other local technical specifications
- c) The repair process for products purchased outside the country of use may require a longer time if the product is not locally sold by TEFAL/T-FAL
- d) In cases where the product is not repairable in the new country, the international TEFAL/T-FAL guarantee is limited to a replacement by a similar product or an alternative product at similar cost, where possible.

Consumer Statutory Rights

This international TEFAL/T-FAL guarantee does not affect the statutory rights a consumer may have or those rights that cannot be excluded or limited, nor rights against the retailer from which the consumer purchased the product. This guarantee gives a consumer specific legal rights, and the consumer may also have other legal rights which vary from State to State or Country to Country. The consumer may assert any such rights at his sole discretion.

Additional information

Accessories, Consumables and end-user replaceable parts can be purchased, if locally available, as described on the TEFAL / T-FAL internet site.

* TEFAL household appliances appear under the T-FAL brand in some territories like America and Japan. TEFAL/T-FAL are registered trademarks of Groupe SEB

: www.tefal.com			
ALGERIA	GRUPE SEB EXPORT Centre du Pail, Base Les AM B0130 ECULLY - FRANCE	213-41 28 18 53	1 year
ARGENTINA	GRUPE SEB ARGENTINA S.A. Bilgosa 4 4111 CALLEVE Capital Federal Buenos Aires	0800-122-2732	2 años
ՀԱՅԱՍՏԱՆ ARMENIA	Պատկարը (Գրախոսություն) 119180 Մոսկով, Մոսկովսկի Մայրուղու 109, ք. Յ. Ե.	(010) 55-76-07	2 տարի/ years
AUSTRALIA	GRUPE SEB AUSTRALIA PO Box 7595 Sydney NSW 2128	02 97487944	1 year
ÖSTERREICH	SEB ÖSTERREICH GmbH Campus 21 - Businesspark West Süd Liebenaustr. A32/702 2548 Sebnitz am Geisinger	01 866 70 299 00	3 Jahre
BELGIQUE / BELGIE	GRUPE SEB BELGIUM SA NV De Avonture de l'Espérance - ZI 6200 Fleurbaey	32 70 23 31 59	2 ans / years
БЕЛАРУСЬ / BELARUS	ЗАО «Група СЕБ-Восток», 119180 Москва, Россиа Славомленский в-д, д. 10 стр. 2	017 2239290	2 годів/ years
BOSNA I HERCEGOVINA	SEB Development Preobelevanje u BiH Vukovica BiH 71000 Sarajevo	Info-linija za potrošače 033 551 220	2 godine
BRASIL	GRUPO SEB DO BRASIL PRODUTOS DOMESTICOS LTDA Avenida Almirante Tamandaré 05108-900 São Paulo, SP	0800-119933	1 ano
БЪЛГАРИЯ/ BULGARIA	ГРУП СЕБ БЪЛГАРИЯ ЕООД ул. Варахор 57, ет. 1, офис 10 1000 София	0700 10 330	2 години
CANADA	GRUPE SEB CANADA 945 Pasmore Avenue Toronto, ON M1Y 3M8	1-800-418-3325	1 year
CHILE	GRUPE SEB CHILE S.p.A. Comercio Ltda Alameda Las Cometas 1707 Providencia Santiago	+56 2 232 77 22	2 años
COLOMBIA	GRUPE SEB COLOMBIA Apartado Aéreo 472 - Kilómetro 1 Vía Elencuela - Calle Condoramarca	18000919288	2 años
HRVATSKA Croatia	SEB Development S.P.A. Vodnjanska 26 10000 Zagreb	01 30 15 294	2 godine
ČESKÁ REPUBLIK / CZECH REPUBLIC	GRUPE SEB ČR spol. s r.o. Jankovcova 1069/2c 170 00 Praha 7	731 010 111	2 roky
DANMARK	GRUPE SEB NORDIC AS Tempova 27 3750 Ballerup	44 663 155	2 år
DEUTSCHLAND	GRUPE SEB DEUTSCHLAND GmbH KRUPS GmbH Helmholtzstr. 03067 Offenbach	0212 387 400	2 Jahre

			
EESTI/ ESTONIA	GRUPE SEB POLSKA SP Z O.O. ul. Ostrobramska 79 04-175 Warszawa	5 800 3777	2 aastat
SUOMI / FINLAND	Grøupe SEB Finland Kutojantie 7 02830 Espoo	09 622 94 20	2 Vuotta
FRANCE Inclus Martinique, Guadeloupe, Réunion & St. Martin	GRUPE SEB France SAS Place Ambroise Courton 69385 Lyon Cedex 06	09 74 50 47 74	1 an
GREECE / ΕΛΛΑΔΑ	SEB GRUPEΣ EKATACOT A.E. 650c Φραγκοκκλησιών 7 Τ.Υ. - 151, 25 Παράδεισος Δραπετσώνα	2106371251	2 χρόνια
HONG KONG	SEB ASIA Ltd Room 801, 9/F, North Block, Skyway House 3 Sham Mong Road, Tai Kok Tsui, Kowloon	852 8130 8998	1 year
MAGYARORSZÁG/ Hungary	GRUPE SEB CENTRAL-EUROPE Kft. Taviró köz 4 2940 Budaörs	(1) 8018434	2 év
INDONESIA	Grøupe SEB Indonesia (Representative office) Sudirman Plaza, Plaza Marein 8th Floor Jl. Jendral Sudirman Kav 75-78, Jakarta 12910, Indonesia	+62 21 5793 6881	1 year
ITALIA	GRUPE SEB ITALIA S.p.A. Via Montefeltro, 4 20156 Milano	199207354	2 anni
JAPAN	GRUPE SEB JAPAN Co. Ltd. 1F Takanawa Muse Building, 3-14-13, Higashi Gotanda, Shinagawa-Ku, Tokyo 141-0022	0570-077772	1 year
ҚАЗАҚСТАН KAZAKHSTAN	«Группа СЕБ-Восток» ЖАҚ, 119180 Москва, Россия Старомонетный түйік көш., 14-үй, 2-құрылыс	727 378 39 39	2 жыл / years
KOREA	(유)그룹 세브 코리아 서울시 동로구 서린동 88 서린빌딩 3층 110-790	1588-1588	1 year
LATVJA / LATVIA	GRUPE SEB POLSKA SP Z O.O. ul. Ostrobramska 79 04-175 Warszawa	6 716 2007	2 gadi
LIETUVA/ LITHUANIA	GRUPE SEB POLSKA SP Z O.O. ul. Ostrobramska 79 04-175 Warszawa	6 470 8888	2 metai
MACEDONIA	Grøupe SEB Bulgaria EOOD Office 1, floor 1, 52G Borovo St., 1680 Sofia - Bulgaria ГРУП СЕБ БЪЛГАРИЯ ДООЕЛ Ул. Борово 52 Г, ет. 1, офис 1, 1680 София, България	(0)2 20 50 022	2 години / years
MALAYSIA	GRUPE SEB MALAYSIA SDN BHD Lot No C/3A/001 & 002, Block C, Kelana Sq No.17, Jalan SS7/26, 47301 Kelana Jaya Petaling Jaya, Selangor	65 6550 8900	1 year
MEXICO	G.S.E.B. MEXICANA, S.A. de C.V. Goldsmith 38 Desp. 401, Col. Polanco Delegación Miguel Hidalgo, 11 560 Mexico D.F.	(01800) 112 8325	1 años

			
MOLDOVA	ТОВ «Грул СЕБ Украина» Вул. Драгоманова 31 Б, офіс 1 02068 Київ, Україна	(22) 929249	2 ani / years
NEDERLAND	GRUPE SEB NEDERLAND BV Generatorsraaf 6 3903 LJ Veenendaal	0318 58 24 24	2 jaar
NEW ZEALAND	GRUPE SEB NEW ZEALAND Unit E, Building 3, 195 Main Highway, Ellerslie, Auckland	0800 700 711	1 year
NORGE	GRUPE SEB NORDIC AS Tempovej 27 2750 Ballerup DANMARK	815 09 567	2 år
PERU	GRUPE SEB COLOMBIA Av. Camino Real N° 111 of. 605 B San Isidro - Lima - Peru	+511 441 4455	1 años
POLSKA/ POLAND	GRUPE SEB POLSKA SP Z O.O. ul. Ostrobramska 79 04-175 Warszawa	0801 300 422 koszt jak za polaczenie lokalne	2 lata
PORTUGAL	GRUPE SEB IBÉRICA SA Urb. da Matinha Rua Projectada à Rua 3 Bloco1 - 3° B/D 1900 - 796 Lisboa	808 284 735	2 anos
REPUBLIC OF IRELAND	GRUPE SEB IRELAND Unit B3 Aerodrome Business Park, College Road, Rathcoole, Co. Dublin	01 677 4003	1 year
ROMÂNIA/ ROMANIA	GRUPE SEB ROMÂNIA Str. Daniel Constantin nr. 8 010632 Bucuresti	0 21 316 87 84	2 ani
РОССИЯ/ RUSSIA	ЗАО «Группа СЕБ-Восток», 119180 Москва, Россия Старомонетный пер. д.14 стр.2	495 213 32 37	2 года/ years
SRBIJA Serbia	SEB Development Antifasistička borbe 17/13 11070 Novi Beograd	060 0 732 000	2 godine
SINGAPORE	GRUPE SEB SINGAPORE Pty Ltd 59 Jalan Pemimpin #04-01/02 L&Y Building, Singapore 577218	65 6550 8900	1 year
SLOVENSKO/ SLOVAKIA	GRUPE SEB SLOVENSKO s.r.o. Rybničná 40 831 07 Bratislava	233 595 224	2 roky
SLOVENIJA	SEB d.o.o Gragorčičeva ulica 6 2000 MARIBOR	02 234 94 90	2 leti
ESPAÑA	GRUPE SEB IBÉRICA S.A. Almogavens, 119-123, Complejo Ecorurban 08018 Barcelona	0902 31 25 00	2 años
SVERIGE	TEFAL SVERIGE SUBSIDIARY OF GROUP SEB NORDIC Truckvägen 14 A, 194 52 Upplanda Väsbj.	08 594 213 30	2 år
SUISSE SCHWEIZ	GRUPE SEB SCHWEIZ GmbH Thurgauerstrasse 105 8152 Glattbrugg	044 837 18 40	2 ans / Jahre
TAIWAN	SEB ASIA Ltd. Taipei International Building, Suite B2, 6F-1, No. 216, Tun Hwa South Road, Sec. 2, Da-an District, Taipei 108, R.O.C.	886-2-27333716	1 year

			
THAILAND	GROUPE SEB THAILAND 2034/66 Hathai Tower, 14th Floor, n° 14-02, New Phetchburi Road, Bangkapi, Huaykwang, Bangkok, 10320	02723 4488	2 years
TÜRKIYE	GROUPE SEB ISTANBUL AS Beybi Giz Plaza Dereboyu Cad. Meydan Sok. No: 28 K.12 Mestak	216 444 40 50	2 YIL
U.S.A.	GROUPE SEB USA 2121 Eden Road Millville, NJ 08332	800-769-3682	1 year
Україна/ UKRAINE	ТОВ «Груп СЕБ Україна» Вул. Драгоманова 31 Б, одиc 1 02088 Київ, Україна	044 492 06 59	2 роки/ years
UNITED KINGDOM	Groupe SEB UK Ltd Riverside House, Riverside Walk Windsor Berkshire, SL4 1NA	0845 602 1454	1 year
VENEZUELA	GROUPE SEB VENEZUELA Av Eugenio Mendoza, Centro Letonia, Torre ING Bank, Piso 15, Ofc 155 Urb. La Castellana, Caracas	0800-7268724	2 anno
VIETNAM	GROUPE SEB VIETNAM (Representative office) 127-129 Nguyen Hue Street District 1, Ho Chi Minh City, Vietnam	+84-8 3821 6395	1 year