

Tefal[®]

ActiFry[®]

EN

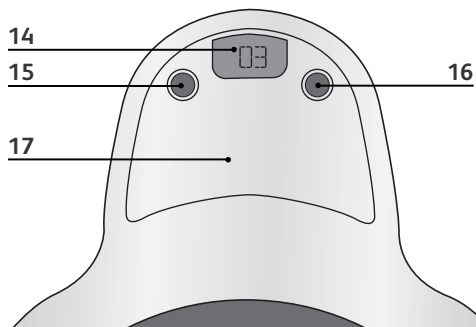

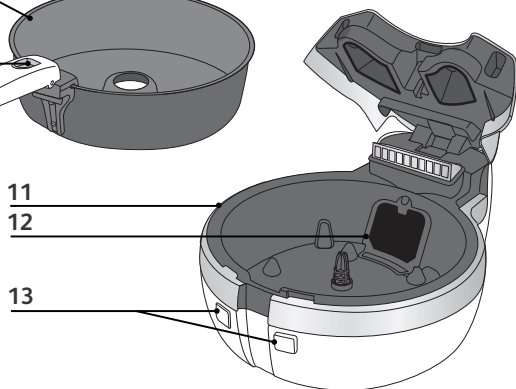
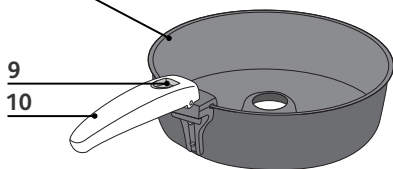
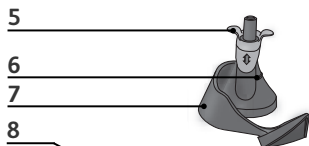
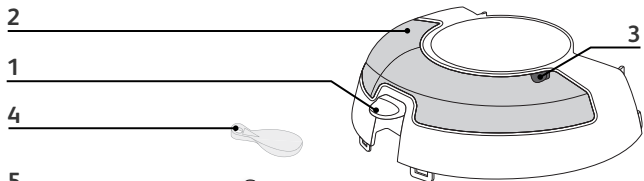

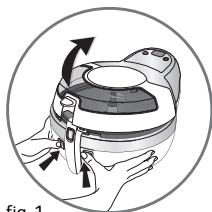

fig. 1

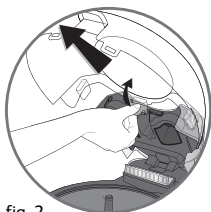

fig. 2

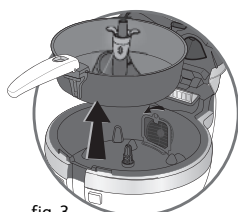

fig. 3

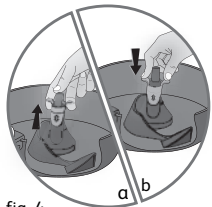

fig. 4



fig. 5

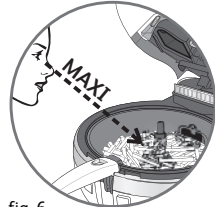

fig. 6



fig. 7



fig. 8

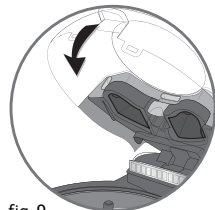

fig. 9

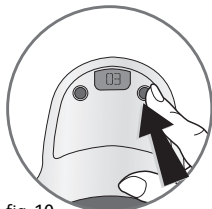

fig. 10



fig. 11

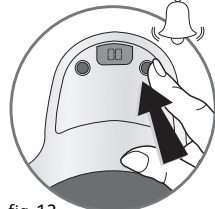

fig. 12



fig. 13



fig. 14

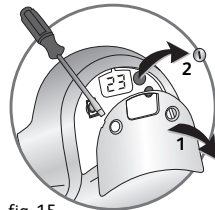

fig. 15

Tefal

Nutritious & Delicious

Innovating for your health's sake

Nutrition is about having a varied and well balanced diet... however it is also about far more than just the ingredients. How they are prepared and cooked can significantly affect their nutritional value, and have a major impact on their taste and texture.

Nutrition is therefore also about the differences in composition between the many preparation methods and cooking appliances available today. With this in mind, **Tefal** has developed a specific range of appliances that are dedicated to NUTRITION FOR GREATER PLEASURE: ingenious culinary appliances which preserve the nutritional integrity and enhance the true taste of the ingredients.

Bringing you unique solutions

Tefal invests in research to bring you unique solutions with nutritional benefits that are validated by scientific studies.

Informing you

For many years **Tefal** has been bringing you appliances which help in the preparation of your meals by providing speed, convenience and ease of use.

Each day, the **Tefal** Nutritious and Delicious range will help you by :

- preserving the quality of the natural ingredients that are essential to your diet,
- limiting the use of fat,
- rediscovering the natural tastes and flavours of food,
- reducing the time spent on the preparation of meals.

Within this range of products, **ActiFry**[®] enables you to prepare 1 kg of potatoes into homemade chips with just 1 spoonful (14 ml) of your favourite oil !

Welcome to the world of ActiFry[®] !

Make real tasty chips just the way you like them!

ActiFry[®] chips are delicious with a crispy coating on the outside and soft and tender inside thanks to the patented technologies: the stirring paddle which gently mixes the food and evenly disperses the oil, and the unique warm air heating system. Choose your ingredients, oil, spices, herbs and seasonings...and let **ActiFry**[®] take care of the rest.

Only 3% fat*: 1 spoonful (14ml) of oil is enough!

One spoonful of the oil of your choice allows you to make real chips from 1kg of potatoes. You can be sure of using exactly the right amount, thanks to the graduated spoon that is supplied with the appliance.

**1 kg of potatoes prepared then cut into fresh chips, to a thickness 13x13 mm and a length of up to approx 9cm, cooked until -55% of weight loss with 14 ml of oil.*

Chips and so much more!

ActiFry[®] enables you to cook a wide variety of recipes.

- In addition to chips and potatoes, you can vary your meals with stir fry cooked vegetables, tender and succulent minced meat dishes, meatballs and crispy fried prawns, shellfish and fruit.



: the + **ActiFry**[®]

The recipe book supplied has been specially created for you by our team of home economists and nutritionists. Apart from traditional chips there are also innovative "fun" ideas for flavoured chips plus recipes for healthy and tasty main meals and even some desserts too!

- The + **ActiFry**[®] cooks frozen food very well too. Frozen foods are a good alternative to fresh products. They are practical and conserve the products' nutritional qualities and taste.

**For the best results with your ActiFry[®],
we advise following our recommendations on
the type of potatoes and oil to use.**

The potato: balance and pleasure on a daily basis!

Potatoes are an excellent source of energy and contain vitamins. Potatoes vary enormously in size, shape and taste according to the variety, climate and growing conditions. Each variety has its particular cropping time, yield, size, colour, keeping quality and culinary uses. A potato's characteristics when cooked may vary according to its origin and seasonality.

Which variety should I use ?

As a general rule, we suggest that you use special potatoes that have been recommended for chipping. In many supermarkets the information on the packaging tells you which varieties are suitable for making chips. We recommend varieties such as King Edward and Maris Piper for good results.

When potatoes have been freshly harvested, they have a higher water content, we recommend cooking the chips for a few more minutes.

Where should I store potatoes?

The best place to store potatoes is in a dark cellar or cool cupboard (between 6 and 8°C), away from the light.

How should I prepare potatoes for ActiFry[®] ?

To obtain the best results, you must ensure that the chips do not stick together. With this in mind, wash the whole potatoes and then cut them into chips using a sharp knife or chip cutter. The chips should be of equal size so that they cook at the same time. Wash the chipped potatoes in plenty of cold water until it runs clear in order to remove as much of the starch as possible. Dry the chips thoroughly using a clean highly absorbent tea towel. The chips must be perfectly dry before putting them in the ActiFry[®] otherwise they will not turn crispy. To check that they are dry enough pat them with paper kitchen towel just before cooking. If there is any wetness on the paper dry them again. Remember the cooking time of the chips will vary according to the weight of chips and the batch of potatoes used.

How should I cut the potatoes?

The size of a chip influences how crunchy or soft it is. The thinner your chips, the more crunchy they will be and conversely, thicker chips will be softer inside. You can cut your chips to the following thickness and length according to your tastes:

Thickness: American style: 8 x 8mm / Thin: 10 x 10mm / Standard: 13 x 13mm

Length: Up to approx 9cm.

In ActiFry the maximum recommended chip thickness is 13mm x 13mm and a length of up to 9cm.

Try a variety of different oils for good health

You can vary the type of oil depending on your choice with 1 ActiFry[®] spoonful of oil for 1 kg of potatoes. Choose a different oil every time you cook!

With ActiFry[®], you can use a very wide variety of oils:

- Standard oils : olive oil, grape seed oil, corn oil, groundnut (peanut) oil, sunflower oil, soya oil*
- Flavoured oils : oils infused with aromatic herbs, garlic, chilli, lemon...
- Speciality oils : hazelnut*, sesame*...

(*cook according to the manufacturers instructions)

With its low quantity of oil for each use, the technology of ActiFry[®] helps in providing a healthier, nutritionally balanced diet.



: the + ActiFry[®]

With ActiFry[®], you can make chips with a better nutritional quality. For extra flavour, you can add 1 or 2 additional spoonfuls of oil for even more taste but this will increase the fat content.

**With + ActiFry[®], make tastier, healthier chips just
as you like them!**

Description

- | | |
|--|--|
| 1. Cool touch area of the lid | 10. Cooking pan handle |
| 2. Lid | 11. Base |
| 3. Latch for removing lid | 12. Removable filter |
| 4. Measuring spoon (14ml) | 13. Lid opening buttons |
| 5. Locking/unlocking paddle lever | 14. Digital timer |
| 6. Maximum food level markers (for chips only) | 15. On/Off switch |
| 7. Removable mixing paddle | 16. Timer setting button |
| 8. Non-stick removable cooking pan | 17. Removable control panel (for access to the battery compartment only) |
| 9. Cooking pan handle release button | |

Quick introduction for use

Before first use

- To remove the lid – **fig.1**, press the lid opening buttons (13) at the same time and lift the latch (3) to take off the lid – **fig. 2**.
 - Remove the measuring spoon.
 - Lift the handle to a horizontal position until you hear a “click” as it locks.
 - Take out the cooking pan – **fig. 3**.
 - To remove the paddle, lift up the light grey colour locking lever positioned on part of the paddle. Position your thumb on the top of the paddle and your index and middle finger under the locking lever, lift up the locking lever using your fingers to unlock the paddle – **fig. 4a**.
 - All the removable parts are dishwasher safe – **fig. 5** or can be washed with a soft sponge and washing up liquid.
 - Wipe the base of the appliance using a damp cloth and washing up liquid.
 - Rinse and dry the parts carefully before putting them back together.
 - To fit the paddle, pull the light grey colour locking lever up, then place the paddle in the middle of the cooking pan and push the locking lever down – **fig. 4b**.
 - During its first use, the appliance may give off a slight odour: this is not harmful and it will disappear quickly. It has no effect on the functioning of your + ActiFry.
- Remove all the stickers and any packaging.**
- Never immerse the base in water.**
- On first use, to obtain the best results from your new product, we advise you to prepare a recipe that cooks for 30 minutes or more.**

Preparing food

For chips, never exceed the maximum level indicated on the paddle – fig. 6. Do not leave the measuring spoon inside the pan when cooking food. Do not leave the measuring spoon inside the pan when cooking food.

- Place the food in the cooking pan, distributing it evenly, making sure that you respect the maximum quantity (see cooking tables p. 7 to 9).
- Add the oil to the food with the spoon – **fig. 7**, spreading it evenly (see cooking tables p. 7 to 9).
(1 spoonful of oil = 14 ml of oil)
- Unlock the handle and fold it completely into its housing – **fig. 8**.
- Close the lid – **fig. 9**.
- Never exceed the maximum quantities of ingredients and liquids indicated in the instruction manual and in the recipe book.

Cooking

- This appliance is not suitable for recipes with a high-liquid content (eg. soups, cook-in sauces...).
- Never turn on the appliance if the cooking pan is empty.
- Do not overfill the cooking pan, never exceed the indicated quantities or maximum food level mark (for chips only).

Set the cooking time

- Press the timer setting button to set the time. Hold down the button until desired time is featured on the display – **fig. 10** (see cooking tables p. 7 to 9).
- Now release. The selected time (in minutes) is displayed and the countdown starts.
- If you make a mistake or to delete the selected time, hold down the button for 2 seconds then set the time again.

BE CAREFUL: the timer signals the end of the cooking but does not switch off the fryer.

Starting the cooking

When you open the lid, the appliance stops working.

- Press the On/Off switch, the cooking begins thanks to the hot air circulation inside the cooking enclosure – **fig.11**. The paddle rotates slowly in a clockwise direction.

Taking food out

- Once cooking is completed, the timer beeps. To stop the beeping signal, press the timer setting button – **fig.12**
- Press on On/Off to stop the appliance – **fig. 13** and open the lid.
- Lift the handle until you hear a “click” that it locks and take out the cooking pan – **fig. 14**.
- Serve at once.

To avoid any risk of burns do not touch the lid or any part other than the cool touch area.

Table of cooking times

The cooking times below are only a guide and may vary according to the variety and batch of potatoes used. We recommend using varieties such as King Edward and Maris Piper for chips and potato recipes.

Potatoes

	TYPE	QUANTITY	OIL	COOKING TIME
Chips standard thickness 13mm x 13mm length up to 9cm	Fresh	1000 g*	1 spoonful oil	40 - 45 min
	Fresh	750 g*	3/4 spoonful oil	35 - 37 min
	Fresh	500 g*	1/2 spoonful oil	28 - 30 min
	Fresh	250 g*	1/4 spoonful oil	24 - 26 min
Potatoes (quartered)	Fresh	1000 g*	1 spoonful oil	40 - 42 min
	Frozen	750 g	None	14 - 16 min
Diced potato	Fresh	1000 g*	1 spoonful oil	40 - 42 min
	Frozen	750 g	None	30 - 32 min
Chips	Frozen - suitable for deep frying only	750 g Standard 13mm x 13mm	None	35-40 min
	Frozen - 2 way or 3 way cook suitable for oven and grill (and deep frying).	750 g Thin 10mm x 10mm	None	30-32 min
		500 g American Style 8mm x 8mm	None	25-27 min

*Weight of unpeeled potatoes

IMPORTANT: To avoid damaging your appliance, never exceed the maximum quantities of ingredients and liquids indicated in the instruction manual and in the recipe book

Other vegetables

	TYPE	QUANTITY	OIL	COOKING TIME
Courgettes	Fresh, in slices	750 g	1 spoonful oil + 150 ml cold water	25 - 35 min
Sweet peppers	Fresh, in slices	650 g	1 spoonful oil + 150 ml cold water	20 - 25 min
Mushrooms	Fresh, in quarters	650 g	1 spoonful oil	12 - 15 min
Tomatoes	Fresh, in quarters	650 g	1 spoonful oil + 150 ml cold water	10 - 15 min
Onions	Fresh, in rings	500 g	1 spoonful oil	15 - 25 min

Meat - Poultry

To add flavour to meat and poultry, mix some spices (such as paprika, curry, mixed herbs, thyme.....) with the oil.

	TYPE	QUANTITY	OIL	COOKING TIME
Chicken nuggets	Fresh	750 g	None	18 - 20 min
	Frozen	750 g	None	18 - 20 min
	Frozen	12 pieces (160 g)	None	12 - 15 min
Chicken drumsticks	Fresh	4 to 6	None	30 - 32 min
Chicken legs	Fresh	2	None	30 - 35 min
Chicken breasts (boneless)	Fresh	6 (about 750 g)	None	10 - 15 min
Chinese Spring Rolls	Fresh	4 to 8 small	1 spoonful oil	10 - 12 min
Lamb chops	Fresh (2.5 cm to 3 cm thick)	2 to 6	None	20 - 25 min*
Pork chops	Fresh (2.5 cm thick)	2 to 3	None	18 - 23 min*
Pork fillet	Fresh	2 to 6 thin slices or strips	1 spoonful oil	12 - 15 min
Sausages	Fresh	4 to 8 (pricked)	None	10 - 12 min
Chilli Con Carne	Fresh (made from minced beef)	500 g	1 spoonful oil	30 - 40 min
Beef steak	Fresh (rump or sirloin cut into 1 cm thick strips)	600 g	None	8 - 10 min
Meatballs	Fresh	12 pieces	None	18 - 20 min

*Turn halfway through cooking

Fish - Shellfish

	TYPE	QUANTITY	OIL	COOKING TIME
Breaded scampi	Frozen	18 pieces (280 g)	None	10 min
Monkfish	Fresh cut in pieces	500 g	1 spoonful oil	20 - 22 min
Prawns	Cooked	400 g	None	10 - 12 min
Jumbo King prawns	Frozen and thawed	300 g (16 pieces)	None	12 - 14 min

	TYPE	QUANTITY	OIL	COOKING TIME
Bananas	Cut in slices	500 g (5 bananas)	1 spoonful oil + 1 spoonful brown sugar	4 - 6 min
	Wrapped in tinfoil	2 bananas	None	20 - 25 min
Cherries	Whole	Up to 1000 g	1 spoonful oil + 1 to 2 spoonful sugar	12 - 15 min
Strawberries	Cut in quarters if large or halves if small	Up to 1000 g	1 to 2 spoonful sugar	5 - 7 min
Apples	Cut in wedges	3	1 spoonful oil + 2 spoonful sugar	15 - 18 min
Pears	Cut in pieces	Up to 1000 g	1 to 2 spoonful sugar	8 - 12 min
Pineapple	Cut in pieces	1	1 to 2 spoonful sugar	8 - 12 min

Frozen products

FOOD	TYPE	QUANTITY	OIL	COOKING TIME
Ratatouille	Frozen	750 g	None	20-22 minutes
Pan-fried fish and pasta	Frozen	750 g	None	20-22 minutes
Pasta carbonara	Frozen	750 g	None	15 - 20 minutes
Paella	Frozen	650 g	None	15 - 20 minutes
Cantonese rice	Frozen	650 g	None	15 - 20 minutes
Chilli con carne	Frozen	750 g	None	112 - 15 minutes

ActiFry cooking hints and tips

- Do not add salt to chips while the chips are in the pan. Only add salt once the chips are removed from the appliance at the end of cooking.
- When adding dried herbs and spices to ActiFry, mix them with some oil or liquid. If you try sprinkling them directly into the pan they will just get blown around by the hot air system.
- Please note that strong coloured spices may slightly stain the paddle and parts of the appliance. This is normal.
- For best results, use finely chopped garlic instead of crushed garlic to avoid it adhering to the central paddle.
- If using onions in ActiFry recipes, they are best thinly sliced instead of chopped as they cook better. Separate the onion rings before adding them to the pan and give them a quick stir so that they are evenly distributed.
- With meat and poultry dishes, stop the appliance and stir the pan once or twice during cooking so that the food on top does not dry out and the dish thickens evenly.
- Prepare vegetables in small pieces or stir fry size to ensure they cook through.
- This appliance is not suitable for recipes with a high-liquid content (eg. soups, cook-in sauces...).

Easy cleaning

Cleaning the appliance

- Leave it to cool down completely before cleaning.
- Open the lid – **fig. 1** and lift the latch to take off the lid – **fig. 2**.
- Lift the handle to the horizontal position until you hear a “click” as it locks – **fig. 3**.
- Take out the cooking pan.
- To remove the mixing paddle, lift up the locking lever – **fig. 4a**.
- Remove the filter by pulling the top – **fig. 3** and wash it.
- All the removable parts are dishwasher safe – **fig. 5** or can be washed with a soft sponge and washing up liquid.
- Clean the base of the appliance using a damp cloth and washing up liquid.
- Rinse and dry parts carefully before putting them back together.
- If food gets stuck or burnt on to the pan or paddle, leave them to soak in warm water before cleaning.
- The appliance has a non-stick cooking pan: the browning and scratches which may appear after long term use do not present any problems and are normal.
- We guarantee that the non-stick coating complies with regulations concerning materials in contact with foodstuffs.

Never immerse the base in water.

Do not use harsh or abrasive cleaning products or scourers.

The removable filter must be cleaned regularly.

To retain the non-stick qualities of the cooking pan for as long as possible, do not use metal utensils when serving food.

Environment protection first!

Timer battery

This appliance uses a button battery – L1154.

- To change the battery remove the control panel with a small flat bladed jewellers screw driver. Prise the control panel up by inserting the screwdriver into the gap at the top of the panel. Remove the white battery cover and replace the battery – **fig 15**. To protect the environment do not throw the old battery in your regular waste but take it to a suitable collection point.
 - Insert a new battery, put the battery cover back on and clip the control panel back on.
- ① Your appliance contains valuable materials which can be recycled.
- ➡ When you decide to replace your appliance, take out the battery and leave the appliance at a local civic waste collection point.



If your fryer is not working correctly

PROBLEMS	CAUSES	SOLUTIONS
The appliance is not working.	The appliance is not plugged in.	Check that the appliance is plugged in correctly.
	The On-Off switch is not fully pressed down.	Press on the On/Off switch.
	You have pressed down the On-Off switch but the appliance is not working.	Close the lid.
	The motor is running but the appliance does not heat.	Contact your point of purchase.
	The paddle does not turn.	Check that the paddle is correctly positioned. If the problem continues, contact your point of purchase.
The removable paddle doesn't stay in place.	The mixing paddle is not locked.	Check that the locking lever has been pushed down fully.
Food is not cooking evenly.	The paddle has not been installed.	Fit the paddle.
	The food has not been cut in regular size pieces.	Cut food to the same size.
	The chips have not been cut in regular size pieces.	Cut the chips to the same size.
	The paddle has been installed correctly but it does not turn.	Check that it has been pushed down and clicked in position. If the problem continues, contact your point of purchase.
The chips are not crispy enough.	The wrong variety of potatoes has been used.	Choose a variety of potato recommended for chips.
	The potatoes are insufficiently washed and/or not completely dried.	Wash the potatoes for a long time to remove excess starch, then drain and dry them before cooking. They must be completely dry.
	The chips are too thick.	Cut the chips thinner. The maximum chips dimensions are 13mm x 13 mm.
	There is not enough oil for the quantity of chips.	Increase the oil quantity (see cooking tables p. 7 to 9).
	The filter is obstructed.	Clean the removable filter.
The chips break up during the cooking.	The potatoes used are recently harvested and hence have a high water content.	Reduce the quantity of potatoes down to 800 g and adjust the cooking time.
The food stays on the edge of the cooking pan.	The cooking pan is too full.	Respect the maximum quantities indicated in the cooking tables.
Cooking liquids have flowed into the base of the appliance.	The paddle is not positioned correctly or the seal of the paddle is defective.	Make sure that the paddle is correctly positioned. If the problem continues, contact your point of purchase. Do not use ActiFry for making soups or recipes with a high liquid content.
The timer does not work.	The battery is dead.	Change the battery (see fig. 15).
The appliance is unusually noisy.	You suspect the motor is not working correctly.	Contact your point of purchase.
The paddle stops turning during cooking.	The paddle is not positioned correctly.	Using an oven glove, push the paddle downward until it clicks into place. If this does not work, contact your point of purchase.

If you have any product problems or queries please contact our Customer Relations Team
Helpline:

0845 602 1454 - UK / (01) 401 8448 - Ireland
or consult our website - www.tefal.co.uk

TEFAL / T-FAL* INTERNATIONAL LIMITED GUARANTEE

 : www.tefal.com

This product is **repairable** by TEFAL / T-FAL, during and after the guarantee period.

The Guarantee

This product is guaranteed by TEFAL / T-FAL (company address and details included in the country list of the TEFAL / T-FAL International Guarantee) against any manufacturing defect in materials or workmanship during the guarantee period within those countries as stated in the Country List on the last page of the user manual, starting from the initial date of purchase.

The international manufacturer's guarantee by TEFAL / T-FAL is an extra benefit which does not affect consumer's Statutory Rights.

The international manufacturer's guarantee covers all costs related to restoring the proven defective product so that it conforms to its original specifications, through the repair or replacement of any defective part and the necessary labour. At TEFAL / T-FAL's choice, a replacement product may be provided instead of repairing a defective product. TEFAL / T-FAL's sole obligation and your exclusive resolution under this guarantee are limited to such repair or replacement.

Conditions & Exclusions

The international TEFAL / T-FAL guarantee only applies within the guarantee period and for those countries listed in the Country List attached and is valid only on presentation of a proof of purchase. The product can be taken directly in person to an authorised service centre or must be adequately packaged and returned, by recorded delivery (or equivalent method of postage), to a TEFAL / T-FAL authorised service centre. Full address details for each country's authorised service centres are listed on TEFAL / T-FAL website (www.tefal.com) or by calling the appropriate telephone number as set out in the Country List to request the appropriate postal address.

TEFAL / T-FAL shall not be obliged to repair or replace any product which is not accompanied by a valid proof of purchase.

This guarantee will not cover any damage which could occur as a result of misuse, negligence, failure to follow TEFAL / T-FAL instructions, use on current or voltage other than as stamped on the product, or a modification or unauthorised repair of the product. It also does not cover normal wear and tear, maintenance or replacement of consumable parts, or the following:

- using the wrong type of water or consumable
- scaling (any de-scaling must be carried out according to the instructions for use)
- ingress of water, dust or insects into the product
- mechanical damages, overloading
- damages or bad results due to wrong voltage or frequency
- accidents including fire, flood, thunderbolt, etc
- professional or commercial use
- damage to any glass or porcelain ware in the product
- replacement of consumables

This guarantee does not apply to any product that has been tampered with, or to damages incurred through improper use and care, faulty packaging by the owner or mishandling by any carrier.

The international TEFAL / T-FAL guarantee applies only for products purchased in one of the countries listed, and used for domestic purposes only in one of the countries listed on the Country List. Where a product purchased in one listed country and then used in another listed country:

- a) The international TEFAL / T-FAL guarantee duration is the one in the country of usage of the product, even if the product was purchased in another listed country with different guarantee duration.
- b) The international TEFAL / T-FAL guarantee does not apply in case of non conformity of the purchased product with the local standards, such as voltage, frequency, power plugs, or other local technical specifications.
- c) The repair process for products purchased outside the country of use may require a longer time if the product is not locally sold by TEFAL / T-FAL.
- d) In cases where the product is not repairable in the new country, the international TEFAL / T-FAL guarantee is limited to a replacement by a similar product or an alternative product at similar cost, where possible.

Consumer Statutory Rights

This international TEFAL / T-FAL guarantee does not affect the statutory rights a consumer may have or those rights that cannot be excluded or limited, nor rights against the retailer from which the consumer purchased the product. This guarantee gives a consumer specific legal rights, and the consumer may also have other legal rights which vary from State to State or Country to Country. The consumer may assert any such rights at his sole discretion.

Additional information

Accessories, consumables and end-user replaceable parts can be purchased, if locally available, as described on the TEFAL / T-FAL internet site.

* TEFAL household appliances appear under the T-FAL brand in some territories like America and Japan. TEFAL/T-FAL are registered trademarks of Groupe SEB.

INTERNATIONAL GUARANTEE : COUNTRY LIST

			
<p>الجزائر ALGERIA</p>	<p>CIJA 9 rue Puvis de Chavannes Saint Euquene Oran</p>	<p>1 an 1 year</p>	<p>(0)41 28 18 53</p>
<p>ARGENTINA</p>	<p>GRUPE SEB ARGENTINA S.A. Billinghurst 1833 3° C1425DTK Capital Federal Buenos Aires</p>	<p>2 años 2 years</p>	<p>0800-122-2732</p>
<p>ՀԱՅԱՍՏԱՆ ARMENIA</p>	<p>ՓԲԸ "Գրուպա ՄԵԲ", 125171, Մոսկվա, Լենինգրադյան խճուղի, 16A, շին.3</p>	<p>2 տարի 2 years</p>	<p>(010) 55-76-07</p>
<p>AUSTRALIA</p>	<p>GRUPE SEB AUSTRALIA PO Box 7535, Silverwater NSW 2128</p>	<p>1 year</p>	<p>02 97487944</p>
<p>ÖSTERREICH AUSTRIA</p>	<p>SEB ÖSTERREICH HmbH Campus 21 - Businesspark Wien Süd Liebermannstr. A02 702 2345 Brunn am Gebirge</p>	<p>2 Jahre 2 years</p>	<p>01 866 70 299 00</p>
<p>BELGIQUE BELGIE BELGIUM</p>	<p>GRUPE SEB BELGIUM SA NV 25 avenue de l'Espérance - ZI 6220 Fleurus</p>	<p>2 ans 2 years</p>	<p>070 23 31 59</p>
<p>БЕЛАРУСЬ BELARUS</p>	<p>ЗАО «Группа СЕБ-Восток», 125171, Москва, Ленинградское шоссе, д. 16А, стр. 3</p>	<p>2 года 2 years</p>	<p>017 2239290</p>
<p>BOSNA I HERCEGOVINA</p>	<p>SEB Développement Predstavništvo u BiH Vrazova 8/II 71000 Sarajevo</p>	<p>2 godine 2 years</p>	<p>Info-linija za potrošače 033 551 220</p>
<p>BRASIL BRAZIL</p>	<p>SEB DO BRASIL PRODUTOS DOMÉSTICOS LTDA Avenida Arno, 146 Mooca 03108-900 São Paulo SP</p>	<p>1 ano 1 year</p>	<p>0800-119933</p>
<p>БЪЛГАРИЯ BULGARIA</p>	<p>ГРУП СЕБ БЪЛГАРИЯ ЕООД Ул. Борово 52 Г, ет. 1, офис 1, 1680 София</p>	<p>2 години 2 years</p>	<p>0700 10 330</p>
<p>CANADA</p>	<p>GRUPE SEB CANADA 345 Passmore Avenue Toronto, ON M1V 3N8</p>	<p>1 an 1 year</p>	<p>800-418-3325</p>
<p>CHILE</p>	<p>GRUPE SEB CHILE Comercial Ltda Av. Providencia, 2331, piso 5, oficina 501 Santiago</p>	<p>2 años 2 years</p>	<p>12300 209207</p>

COLOMBIA	GRUPE SEB COLOMBIA Apartado Aereo 172, Kilometro 1 Via Zipaquira Cajica Cundinamarca	2 años 2 years	18000919288
HRVATSKA CROATIA	SEB Developpement S.A.S. Vodnjanska 26 10000 Zagreb	2 godine 2 years	01 30 15 294
ČESKÁ REPUBLIK CZECH REPUBLIC	GRUPE SEB ČR spol. s r. o. Jankovcova 1569/2c 170 00 Praha 7	2 roky 2 years	731 010 111
DANMARK DENMARK	GRUPE SEB NORDIC AS Tempovej 27 2750 Ballerup	2 år 2 years	44 663 155
DEUTSCHLAND GERMANY	GRUPE SEB DEUTSCHLAND GmbH / KRUPS GmbH Herrnrainweg 5 63067 Offenbach	2 Jahre 2 years	0212 387 400
EESTI ESTONIA	GRUPE SEB POLSKA Sp. z o.o. ul. Bukowińska 22b 02-703 Warszawa	2 aastat 2 years	5 800 3777
SUOMI FINLAND	Groupe SEB Finland Kutojantie 7 02630 Espoo	2 Vuotta 2 years	09 622 94 20
FRANCE Incluant uniquement Guadeloupe, Martinique, Réunion, Saint-Martin	GRUPE SEB FRANCE Service Consommateur Tefal BP 15 69131 ECULLY CEDEX	1 an 1 year	09 74 50 47 74
ΕΛΛΑΔΑ GREECE	SEB GROUPE ΕΛΛΑΔΟΣ Α.Ε. Οδός Καβαλιεράτου 7 Τ.Κ. 145 64 Ν. Κηφισιά	2 χρόνια 2 years	2106371251
香港 HONG KONG	SEB ASIA Ltd. Room 903, 9/F, South Block, Skyway House 3 Sham Mong Road, Tai Kok Tsui, Kowloon Hong-Kong	1 year	852 8130 8998
MAGYARORSZÁG HUNGARY	GRUPE SEB CENTRAL-EUROPE Kft. Táviró köz 4 2040 Budaörs	2 év 2 years	06 1 801 8434
INDONESIA	GRUPE SEB INDONESIA (Representative office) Sudirman Plaza, Plaza Marein 8th Floor JL Jendral Sudirman Kav 76-78, Jakarta 12910, Indonesia	1 year	+62 21 5793 6881
ITALIA ITALY	GRUPE SEB ITALIA S.p.A. Via Montefeltro, 4 20156 Milano	2 anni 2 years	199207354
JAPAN	GRUPE SEB JAPAN Co. Ltd. 1F Takanawa Muse Building, 3-14-13, Higashi Gotanda, Shinagawa-Ku, Tokyo 141-0022	1 year	0570-077772

ҚАЗАҚСТАН KAZAKHSTAN	ЖАҚ «Группа СЕБ- Восток» 125171, Мәскеу, Ленинградское шоссесі, 16А, 3 үйі	2 жыл 2 years	727 378 39 39
한국어 KOREA	(유)그룹 세브 코리아 서울시 종로구 서린동 88 서린빌딩 3 층 110-790	1 year	1588-1588
LATVIJA LATVIA	GROUPE SEB POLSKA Sp. z o.o. ul. Bukowińska 22b 02-703 Warszawa	2 gadi 2 years	6 716 2007
LIETUVA LITHUANIA	GROUPE SEB POLSKA Sp. z o.o. ul. Bukowińska 22b 02-703 Warszawa	2 metai 2 years	6 470 8888
LUXEMBOURG	GROUPE SEB BELGIUM SA NV 25 avenue de l'Espérance - ZI 6220 Fleurus	2 ans 2 years	0032 70 23 31 59
MACEDONIA	Groupe SEB Bulgaria EOOD Office 1, floor 1, 52G Borovo St., 1680 Sofia - Bulgaria ГРУП СЕБ БЪЛГАРИЯ ДООЕЛ Ул. Борово 52 Г, сп. 1, офис 1, 1680 София, България	2 години 2 years	(0)2 20 50 022
MALAYSIA	GROUPE SEB MALAYSIA SDN. BHD Lot No.C/3A/001 & 002, Block C, Kelana Square No.17, Jalan SS7/26, 47301 Kelana Jaya Petaling Jaya, Selangor	1 year	65 6550 8900
MEXICO	Groupe S.E.B. México, S.A. DE C.V. Goldsmith 38 Desp. 401, Col. Polanco Delegación Miguel Hidalgo 11 560 México D.F.	1 año 1 year	(01800) 112 8325
MOLDOVA	ТОВ «Груп СЕБ Україна» 02121, Харківське шосе, 201-203, 3 поверх, Київ, Україна	2 ani 2 years	(22) 929249
NEDERLAND The Netherlands	GROUPE SEB NEDERLAND BV Generatorstraat 6 3903 LJ Veenendaal	2 jaar 2 years	0318 58 24 24
NEW ZEALAND	GROUPE SEB NEW ZEALAND Unit E, Building 3, 195 Main Highway, Ellerslie, Auckland	1 year	0800 700 711
NORGE NORWAY	GROUPE SEB NORDIC AS Tempovej 27 2750 Ballerup DANMARK	2 år 2 years	815 09 567
PERU	Groupe SEB Perú Av. Camino Real N° 111 of. 805 B San Isidro - Lima – Perú	1 año 1 year	441 4455

POLSKA POLAND	GRUPE SEB POLSKA Sp. z o.o. ul. Bukowińska 22b 02-703 Warszawa	2 lata 2 years	0801 300 421 koszt jak za połączenie lokalne
PORTUGAL	GRUPE SEB IBÉRICA SA Urb. da Matinha Rua Projectada à Rua 3 Bloco1 - 3° B/D 1950 - 327 Lisboa	2 anos 2 years	808 284 735
REPUBLIC OF IRELAND	GRUPE SEB IRELAND Unit B3 Aerodrome Business Park, College Road, Rathcoole, Co. Dublin	1 year	01 677 4003
ROMÂNIA ROMANIA	GRUPE SEB ROMÂNIA Str. Daniel Constantin nr. 8 010632 București	2 ani 2 years	0 21 316 87 84
РОССИЯ RUSSIA	ЗАО «Группа СЕБ-Восток», 125171, Москва, Ленинградское шоссе, д. 16А, стр. 3	2 года 2 years	495 213 32 30
SRBIJA SERBIA	SEB Developpement Đorđa Stanojevića 11b 11070 Novi Beograd	2 godine 2 years	060 0 732 000
SINGAPORE	GRUPE SEB SINGAPORE Pty Ltd. 59 Jalan Pemimpin, #04-01/02 L&Y Building Singapore 577218	1 year	65 6550 8900
SLOVENSKO SLOVAKIA	GRUPE SEB Slovensko, spol. s r.o. Rybničná 40 831 06 Bratislava	2 roky 2 years	233 595 224
SLOVENIJA SLOVENIA	SEB d.o.o Gregorčičeva ulica 6 2000 MARIBOR	2 leti 2 years	02 234 94 90
ESPAÑA SPAIN	GRUPE SEB IBÉRICA S.A. C/ Almogàvers, 119-123, Complejo Ecourban 08018 Barcelona	2 años 2 years	902 31 24 00
SVERIGE SWEDEN	TEFAL SVERIGE SUBSIDIARY OF GROUP SEB NORDIC Truckvägen 14 A, 194 52 Upplands Väsby	2 år 2 years	08 594 213 30
SUISSE CHWEIZ SWITZERLAND	GRUPE SEB SCHWEIZ GmbH Thurgauerstrasse 105 8152 Glattbrugg	2 ans 2 Jahre 2 years	044 837 18 40
TAIWAN	SEB ASIA Ltd. Taipei International Building, Suite B2, 6F-1, No. 216, Tun Hwa South Road, Sec. 2 Da-an District Taipei 106, R.O.C.	1 year	886-2-27333716
THAILAND	GRUPE SEB THAILAND 2034/66 Italthai Tower, 14th Floor, n° 14-02, New Phetchburi Road, Bangkapi, Huaykwang, Bangkok, 10320	2 years	662 351 8911

TÜRKIYE TURKEY	GRUPE SEB ISTANBUL AS Beybi Giz Plaza Dereboyu Cad. Meydan Sok. No: 28 K.12 Maslak	2 YIL 2 years	216 444 40 50
U.S.A.	GRUPE SEB USA 2121 Eden Road Millville, NJ 08332	1 year	800-395-8325
Україна UKRAINE	ТОВ «Груп СЕБ Україна» 02121, Харківське шосе, 201-203, 3 поверх, Київ, Україна	2 роки 2 years	044 492 06 59
UNITED KINGDOM	GRUPE SEB UK LTD Riverside House Riverside Walk Windsor Berkshire,SL4 1NA	1 year	0845 602 1454
VENEZUELA	GRUPE SEB VENEZUELA Av Eugenio Mendoza, Centro Letonia, Torre ING Bank, Piso 15, Ofc 155 Urb. La Castellana, Caracas	2 años 2 years	0800-7268724
VIETNAM	GRUPE SEB VIETNAM (Representative office) 127-129 Nguyen Hue Street District 1, Ho Chi Minh City, Vietnam	1 year	+84-8 3821 6395

 : www.tefal.com

