

Easy-Fry & Pro-Fry

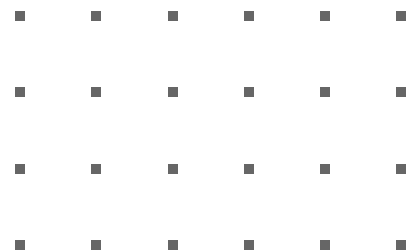

Fryer

Instructions for use



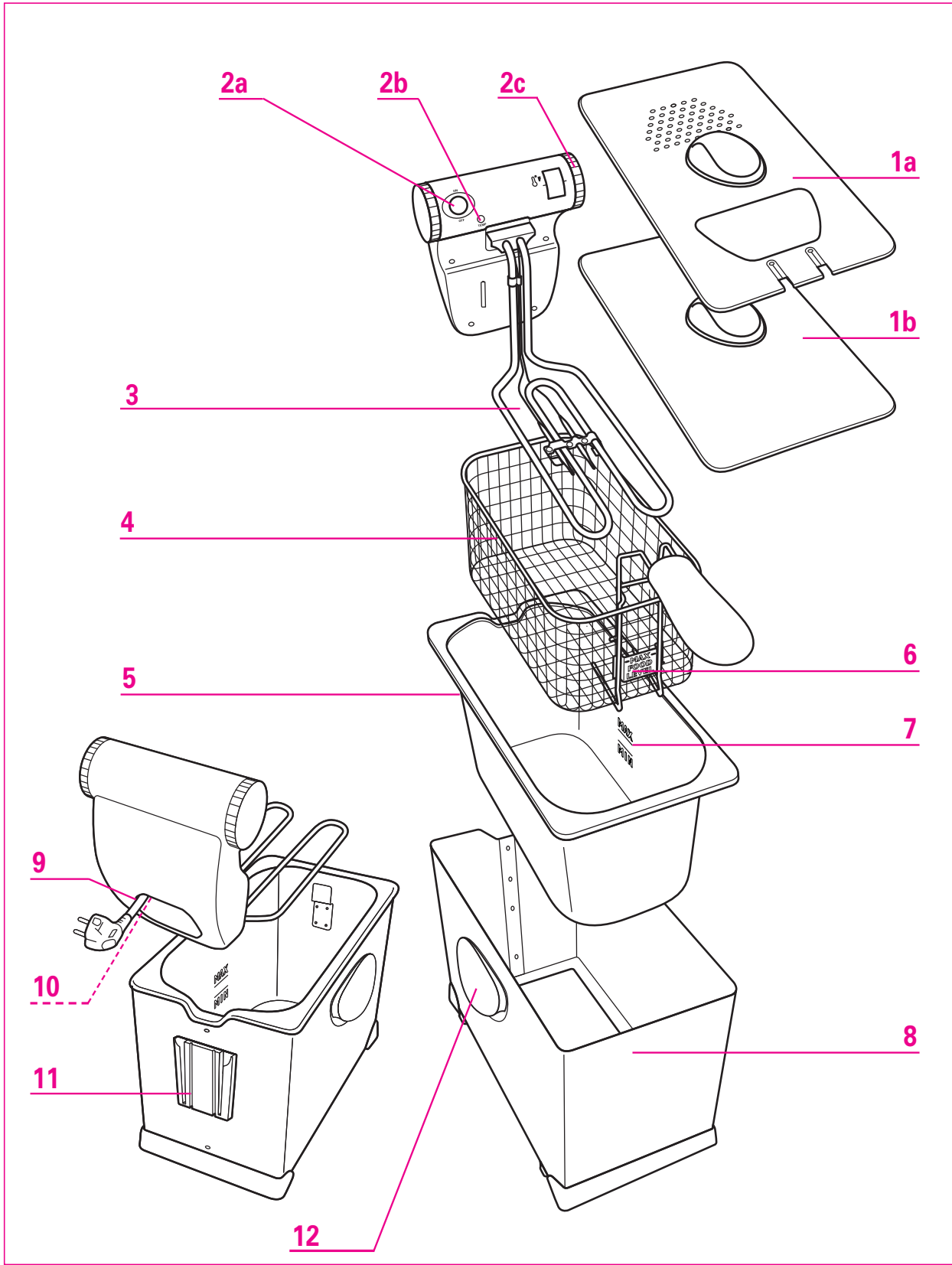

Description

- | | |
|--|---|
| <ol style="list-style-type: none"> 1. Lid (depending on model) <ol style="list-style-type: none"> a. with window and metallic filter b. for storage 2. Removable control unit <ol style="list-style-type: none"> a. On / Off switch with indicator light b. Temperature-setting indicator light c. Adjustable thermostat 3. Removable heating element with temperature-control sensors | <ol style="list-style-type: none"> 4. Frying basket with handle 5. Removable stainless-steel bowl with pouring spout 6. Basket maximum filling level 7. Min. and Max. oil level markers 8. Stainless-steel or white enamelled-metal casing (depending on model) 9. Cord storage 10. Reset button 11. Positioning grooves for control unit 12. Carrying handles |
|--|---|

Protection of the environment

- Your appliance has been designed to work for many years. However, when you finally decide to replace it, do not forget to think about protecting the environment by disposing of it at your local waste disposal centre.

Helpline

for any problems or queries please telephone

0845 602 14 54	-	UK (calls charged at local rates)
(01) 412 3000	-	Ireland

or consult our web site

www.tefal.co.uk

For UK users only - Wiring instructions

Warning:

this appliance must be earthed.

Important:

the wires in this cord are coloured in accordance with the following codes :

Green and Yellow: Earth

Blue: Neutral

Brown: Live

- Connect the Green/Yellow wire to the terminal in the plug marked "E" (or by the earth symbol) or coloured Green or coloured Green and Yellow. Connect the Brown wire to the terminal in the plug marked "L" or coloured Red. Connect the Blue wire to the terminal in the plug marked "N" or coloured Black. A 13 amp fuse should be fitted when the appliance is connected to a BS 1363 plug. Seek professional advice if you are unsure of the correct procedure of the above.

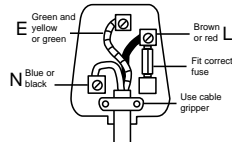

About your factory fitted plug.FOR UK ONLY (supplied with certain models only)

- The cord is already fitted with a plug incorporating a 13 amp fuse. If the plug does not fit your socket outlet, see next paragraph.
- Should you need to replace the fuse in the plug supplied, a 13 amp approved BS 1362 fuse must be used.
- The fuse cover is an important part of the plug. Please ensure that it is always refitted. If you lose this cover please do not use the plug. You may contact TEFAL for a replacement.
- If the plug supplied does not fit your socket outlet, it should be removed from the mains cord and disposed of safely. The flexible cord insulation should be stripped back as appropriate and a suitable alternative plug fitted. The replacement plug must be equipped with a 13 amp fuse.

Important:

if the electrical cord of this appliance is damaged, it must only be replaced by an authorised Service Dealer. The safety of this appliance complies with the technical regulations and standards in force.

Voltage

- This appliance is designed to work on 230-240 volts AC only. Check that the mains supply corresponds to that shown on the rating plate of the appliance. If the appliance is to be used in any country other than that of purchase, it should be checked by an approved Service Dealer. Standards can vary from country to country.

Safety instructions

- This appliance complies with current safety regulations and requirements as well as directives:
 - 89/336/CEE modified by 93/68/CEE
 - 73/23/CEE modified by 93/68/CEE
 - This electrical appliance operates at high temperatures which may cause burns. Despite the high heat protection of the deep fryer, do not touch the apparent metal parts.
- Do not leave the appliance switched on while unattended.
- The basket handle may become hot after prolonged use.
 - Use and store it out of children's reach.
 - Never insert any object between the removable bowl and the bottom of the appliance
 - Always plug in the appliance at an earthed power socket.
 - Do not use an extension lead. If you accept liability for doing so, only use an extension lead which is in good condition, has an earthed plug, and is suited to the power of the appliance.
 - Check that the mains voltage corresponds with that shown on the appliance (alternating current only).
 - If the appliance is used in a country other than that of purchase, have it checked by an approved Service Centre.
- Never use or plug in your appliance if:
 - its power cord is faulty or damaged,
 - the appliance has been dropped,
 - it has visible damage or operating faults.
 In such cases, to avoid any danger contact your nearest approved Service Centre to have the appliance repaired, as special tools are needed. Never dismantle the appliance yourself. This will negate the guarantee.
 - If the power cord is damaged, it must be replaced by an authorised service centre, in order to avoid any danger.
 - In the event of fire, never try to extinguish the flames with water. Close the lid. Smother the flames with a damp cloth.
 - Do not switch on the appliance near to inflammable materials (blinds, curtains, etc.) or close to an external heat source (gas stove, hotplate, etc.)
 - This appliance has been designed for domestic use only. Any professional use, inappropriate use or failure to comply with the instructions, the manufacturer accepts no responsibility and the guarantee does not apply.

Preparation for use

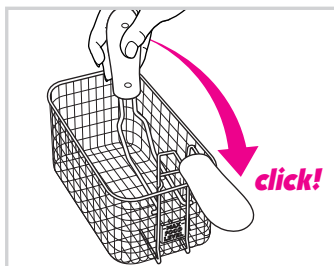

Before using your deep fryer for the first time

- Completely unfold the basket handle; a click indicates that it is correctly positioned.
- Remove the control unit and the bowl.
- Clean the lid, the bowl and the frying basket with a damp cloth and washing-up liquid. Rinse and dry thoroughly.
- Clean the other components of the fryer with a damp cloth.

! Never immerse the control unit, the heating element, or the power cable in water or any other liquid.

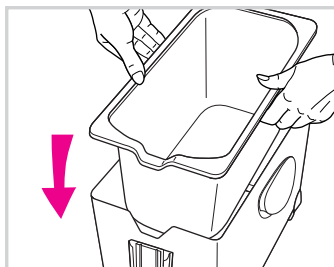

Replacing the removable bowl

- Insert the bowl into the deep fryer : the rim holds the bowl firmly in position.

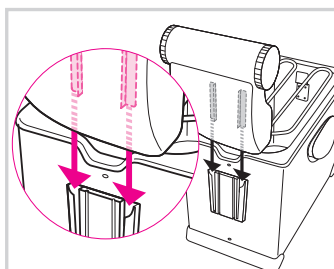

- Use the guide slots to position the control unit correctly.
- Your fryer is fitted with a safety system. The heating element will not function if it is badly positioned or removed from the deep fryer.

! Make sure that the control unit is correctly positioned otherwise the fryer cannot function.

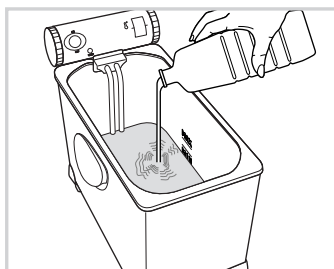

Filling the bowl

- For best results we recommend blended vegetable oil. For sunflower oil, groundnut oil, or soya oil ensure the oil is changed after every 5 uses.
- If you use solid vegetable fat:
 - Cut into small pieces, melt in a separate pan and pour the melted fat into the fryer bowl.
 - When remelting solidified fat, break up the surface with a fork to prevent splashes. Take care not to damage the heating element or temperature sensors.
 - Never exceed 150°C to melt it, then follow the manufacturer's cooking instructions.
- Lard or dripping should **NOT** be used under any circumstances and may cause overflowing, smoking or risk of fire. For traditional UK style deep fried foods, especially chips, we do not recommend using olive oil.

! Never plug in the deep fryer without oil or fat inside.

! Do not mix different types of oils.

! The oil level must always be between the Min. and Max. markers. Check this each time before cooking, and add some of the same type of oil if necessary.

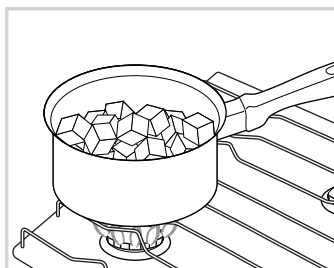

Preparation for use

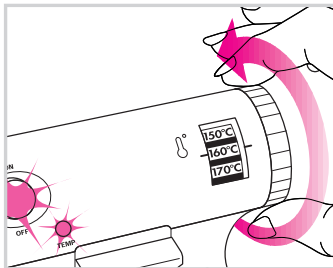
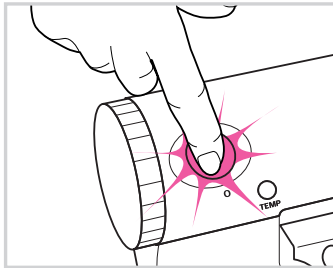

Preheating

- Plug in the deep fryer.
- Switch on the fryer using the On/ Off button : the indicator light will go on.
- Turn the temperature control to the desired setting (see cooking table) : the temperature indicator light will come on.
- If you are making fresh chips, do not forget to set the thermostat to 160° for the first fry and to 190° for the second fry.
- Do not use the lid during cooking unless it is fitted with a metallic filter and a window.

- ! Place the deep fryer:
 - on a steady surface,
 - out of the reach of children,
 - away from water splashes or heat sources.
- ! Do not leave the fryer unattended. Do not allow the cord to hang down from the worksurface.

Preparing the basket

- Place food in the frying basket. Do not overfill the basket. Never exceed the basket maximum filling level.

- ! Never exceed the maximum capacity.



- Cut the foods into like-sized pieces so that they cook evenly,
- Avoid using pieces that are too thick.
- Wipe food dry with absorbent paper before frying it.
- Shake frozen foods to detach pieces of ice away from the deep fryer.
- Not all frozen foods are ready to use. Check the manufacturer's instructions.

	Fresh potato chips	Frozen potato chips
PRO & FRY and EASY FRY 4 L		
Maximum recommended quantity for double frying	800 g	700 g
PRO & FRY and EASY FRY 3 L		
Maximum recommended quantity for double frying	600 g	500 g

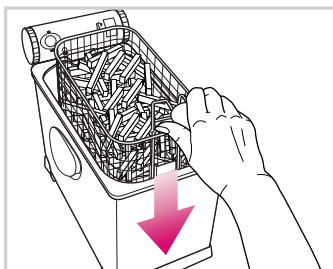

Lowering the basket

- After the indicator light has gone out, lower the basket slowly into the frying oil.
- Use the lid only if it is fitted with a metallic filter and a window.

- ! Plunging the basket too rapidly into the oil may cause it to overflow.

Cooking

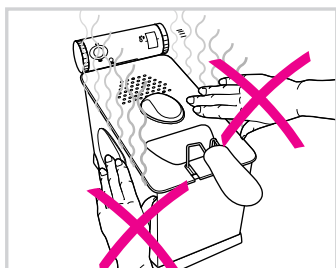

Keep an eye on the cooking

- During cooking, it is normal for the temperature indicator light to go on and go off during cooking.
- Always double fry freshly made chips .
 - a first fry for 8 to 10 minutes at 160 °C
 - a second fry for 2 to 4 minutes at 190 °C
- frozen chips are pre-cooked, you may be able to fry them just once, depending on the instructions on the packet.

! The steam coming from the filter is extremely hot ; so are the window and the metallic parts .
Caution: never place your hand or your face over the lid. Never remove the bowl while the deep fryer is switched on.

! To prepare several helpings of fresh chips, prepare the desired quantity at 160 °C, then fry at 190 °C just before serving.

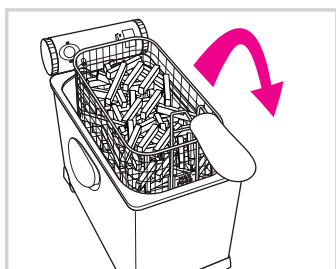

Removing the food

- Lift the frying basket out of the oil and rest it on the rim of the bowl.
- Let it drain for a few seconds.
- Take the basket away from the fryer.
- Serve.

! When you take off the lid, never drain it over the oil.



Add salt and pepper away from the deep fryer to avoid getting in the oil.

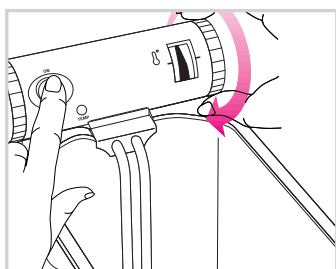

Switching off the deep fryer

- When you have finished frying, set the temperature control to the lowest setting and the power switch to the OFF position.
- Unplug the deep fryer.

! Never move your deep fryer with hot oil inside.

If the fryer contains fat, allow the fat to solidify in the fryer and store it with the fat inside.

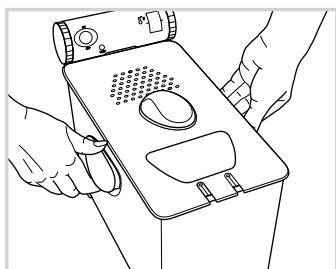

- Leave the deep fryer to cool completely (1 to 2 hours).
- Store the power cord in the cord storage.
- Use only the carrying handles to move the deep fryer.

Cooking

Cooking tables

The cooking times are a guide only. They could vary depending on quantity, taste, electricity supply etc...

Fresh foods	Temperature	Cooking time
Potato chips : 1 st fry (600 g - model 3 L)	160°	6 to 7 min.
Potato chips : 2 nd fry (600 g - model 3 L)	190°	1 to 2 min.
Potato chips : 1 st fry (800 g - model 4 L)	160°	7 to 8 min.
Potato chips : 2 nd fry (800 g - model 4 L)	190°	1 to 2 min.
Breaded Camembert wedges (250 g)	190°	1 min.
Potato croquettes (8-10 pieces)	190°	8 to 9 min.
Poultry croquettes (8 pieces)	180°	14 to 15 min.
Spring rolls (8-10 pieces)	180°	4 to 5 min.
Vegetable fritters (12-15 pieces)	170°	10 to 12 min.
Apple Fritters (8-9 pieces)	170°	5 to 6 min.
Ring doughnuts* (12-15 pieces)	170°	7 to 9 min.
Fried Whole Mushrooms (500 g - model 4 L)	150°	10 to 12 min.
Fried Whole Mushrooms (400 g - model 3 L)	150°	8 to 10 min.

* = These thicker foods may require turning halfway through cooking to ensure even cooking on both sides.

Frozen foods	Quantity	Cooking time at 190°
Potato chips (pre-cooked)	400 g	4 to 5 min.
Potato chips (pre-cooked)	500 g	5 to 6 min.
Potato chips (pre-cooked) (model 4 L)	700 g	10 to 12 min.
American style Thin Cut chips	400 g	5 to 6 min.
Potato croquettes	10-12 pieces	5 to 6 min.
Fish fingers	12 pieces	5 to 6 min.
Chicken nuggets	16 pieces	7 to 8 min.
Poultry croquettes	10-12 pieces	5 to 6 min.
Spring rolls	8-10 pieces	5 to 6 min.
Scampi fritters	12-15 pieces	5 to 6 min.
Apple fritters	8-9 pieces	5 to 7 min.



Always fry freshly made chips twice.

- a first fry at 160 °C

- a second fry at 190 °C

For the crispiest results, dry food items thoroughly before frying, especially freshly made chipped potatoes.

Large pieces of chicken or large chips need a longer cooking time.

Set the temperature control according to the table above, or follow the instructions on food packaging.

Cooks tips : When cooking battered food and doughnuts, remove the wire basket to prevent food sticking to it. Take great care when handling the food and use tongs. Gradually place the food in the hot oil, submerging it an inch at a time to prevent it from sinking straight away.

Maintenance and cleaning

Storing the oil

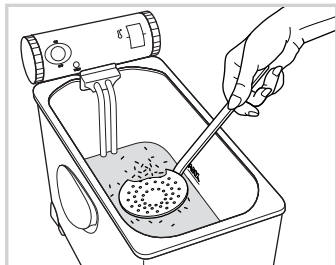

- Turn off the fryer and wait until the oil has completely cooled.
- Remove the small pieces of food remaining in the oil with a non-metallic skimmer.
- Keep the oil in the deep fryer or store it in an air-tight container away from heat and light sources. (recommended if you do not use the deep fryer often).

! It is not necessary to store oil in a refrigerator.

Changing the oil/fat

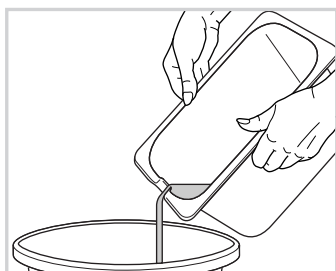

- Do not pour used oil into the sink. Leave it to cool and throw it away with the household waste.

! Change the oil after being used for 8 to 12 times maximum

• "Clean" oil keeps the flavour and lightness of food and avoids bad odours.

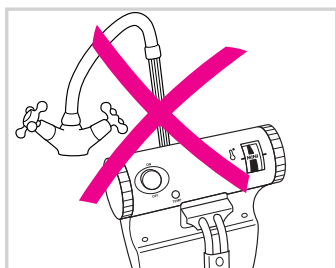

Cleaning the fryer



Exclusive MAGICLEAN® : very easy to clean : the basket, lid and bowl of the deep fryer can be cleaned in the dishwasher .

- Clean the control unit and the exterior of the fryer with a damp cloth. Dry thoroughly.
- This fryer is fitted with a built-in filter. The filter must be cleaned regularly to ensure efficient operation.
- Allow the lid to dry thoroughly before re-use.
- Try not to damage the bowl through bumps or being dropped.

! Never immerse the control unit in water.

Do not use aggressive or abrasive cleaning products.

! If the lid or basket is bent out of shape, obtain a replacement from your nearest Approved Service Centre.

! If the frying bowl is damaged, obtain a replacement from your nearest Approved Service Centre.

If your deep fryer does not work properly

Problem and possible causes	Solutions
The deep fryer does not work	
<ul style="list-style-type: none"> The power switch is not in the ON position. The safety system is operating. The control unit is not correctly positioned. 	<ul style="list-style-type: none"> Switch the power on and check that the temperature indicator light comes on. Press the "reset" button, which is located in the power cord storage compartment. To prevent this, use the guide slots to correctly position the control unit.
The frying oil overflows	
<ul style="list-style-type: none"> The Max. marker for filling the bowl has been exceeded. Foods are wet or contain too much water (frozen foods). The basket lowering was too rapid. Different types of oil/fat have been mixed. Overflowing of oil/fat. Cooking freshly made chips at 180°/190° for the first fry. Too much water on the food when it was immersed in hot cooking oil. 	<ul style="list-style-type: none"> Check the oil level (Max.), and remove the excess. Fry the foods in small quantities (particularly frozen foods). Lower the basket slowly and keep a close eye on the oil level. Empty and clean the bowl. Refill the bowl with one type of oil (see page 3). Remove any ice and dry the foods thoroughly. Lower the basket very slowly. It is important to double-fry freshly made chips and to respect the recommended cooking temperature.(see page 5 and 6). Dry food thoroughly.
The oil overflows during the second frying.	
<ul style="list-style-type: none"> The cooking time of the first fry was too short. 	<ul style="list-style-type: none"> Increase cooking time for the first frying.
The foods do not become golden, and remain soft	
<ul style="list-style-type: none"> The cooking temperature is too low. The frying basket is overloaded. 	<ul style="list-style-type: none"> Set the thermostat to the recommended temperature. Fry the foods in small quantities
The chips stick together	
<ul style="list-style-type: none"> The oil is not hot enough. Unwashed food immersed in hot oil. 	<ul style="list-style-type: none"> Defective thermostat. Contact your retailer or Approved Service Centre. Wash potatoes well and dry them thoroughly.
Unpleasant odours	
<ul style="list-style-type: none"> Not changing the oil often enough Unsuitable oil or fat has been used. 	<ul style="list-style-type: none"> Renew the oil after 8 to 12 uses (see page 3). Use a good quality vegetable oil (see page 3).

If the problem remains, check with your stockist or an Approved Service Centre.

Any repairs must only be carried out by an Approved Service Centre with the manufacturer's own replacement parts.

HELPLINE : 0845 602 14 54 - UK (calls charged at local rates)
(01) 412 3000 - Ireland

Consult our web site: www.tefal.co.uk

Easy-Fry & Pro-Fry

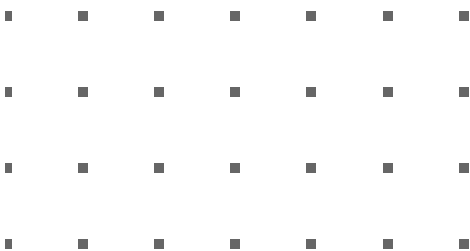

REF 5063008A